



512K x 32 Module nvSRAM

5.0V High Speed SRAM with Non-Volatile Storage

AVAILABLE AS MILITARY SPECIFICATIONS

- Military Processing (MIL-STD-883C para 1.2.2)
- Temperature Range -55C to 125C

FEATURES

- -55°C to 125°C Operation
- True non-volatile SRAM (no batteries)
- 20 ns, 25 ns, and 45 ns access times
- Automatic STORE on power down with only a small capacitor
- STORE to QuantumTrap® nonvolatile elements initiated by software, device pin, or AutoStore® on power down
- RECALL to SRAM initiated by software or power up
- Infinite Read, Write, and Recall cycles
- 200,000 STORE cycles to QuantumTrap
- 20 year data retention
- Single 5.0V ±10% power supply
- Ceramic Hermetic 68 Quad Flat Pak
 - Matches compatible pinout footprint of SRAM & EEPROM Module

PIN ASSIGNMENT (Top View)

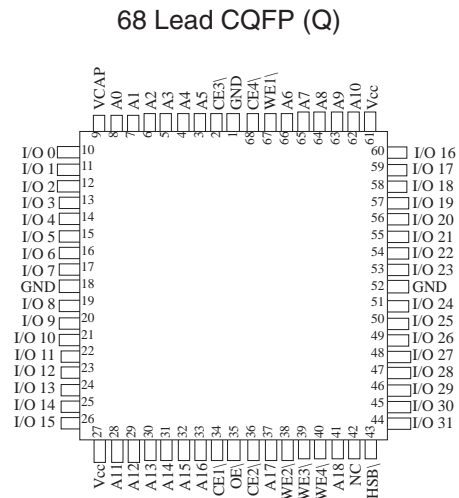



Pin Name	I/O Type	Description
A0 – A18	Input	Address Inputs Used to Select one of the 524,288 32-bit words of the nvSRAM.
DQ0 – DQ7	Input/Output	Bidirectional Data I/O Lines for die M1 (DQ0-7), M2 (DQ8-15), M3 (DQ16-23), M4 (DQ 24-31)
DQ8 – DQ15		
DQ16 – DQ23		
DQ24 – DQ31		
WE ₁₋₄	Input	Write Enable Input, Active LOW. When selected LOW, data on the I/O pins is written to the specific address location.
CE ₁₋₄	Input	Chip Enable Input, Active LOW. When LOW, selects the chip. When HIGH, deselects the chip.
OE ₁₋₄	Input	Output Enable, Active LOW. The active LOW OE input enables the data output buffers during read cycles. I/O pins are tri-stated on deasserting OE HIGH.
V _{SS}	Ground	Ground for the Device. Must be connected to the ground of the system.
V _{CC}	Power Supply	Power Supply Inputs to the Device.
HSB ₁₋₄	Input/Output	Hardware Store Busy (HSB ₁₋₄). When LOW this output indicates that a hardware store is in progress. When pulled LOW external to the chip it initiates a nonvolatile STORE operation. A weak internal pull up resistor keeps this pin HIGH if not connected (connection optional). After each store operation HSB ₁₋₄ is driven HIGH for short time with standard output high current.
V _{CAP}	Power Supply	AutoStore Capacitor. Supplies power to the nvSRAM during power loss to store data from SRAM to nonvolatile elements.
NC	No Connect	No Connect. This pin is not connected to the die.

LOGIC BLOCK DIAGRAM

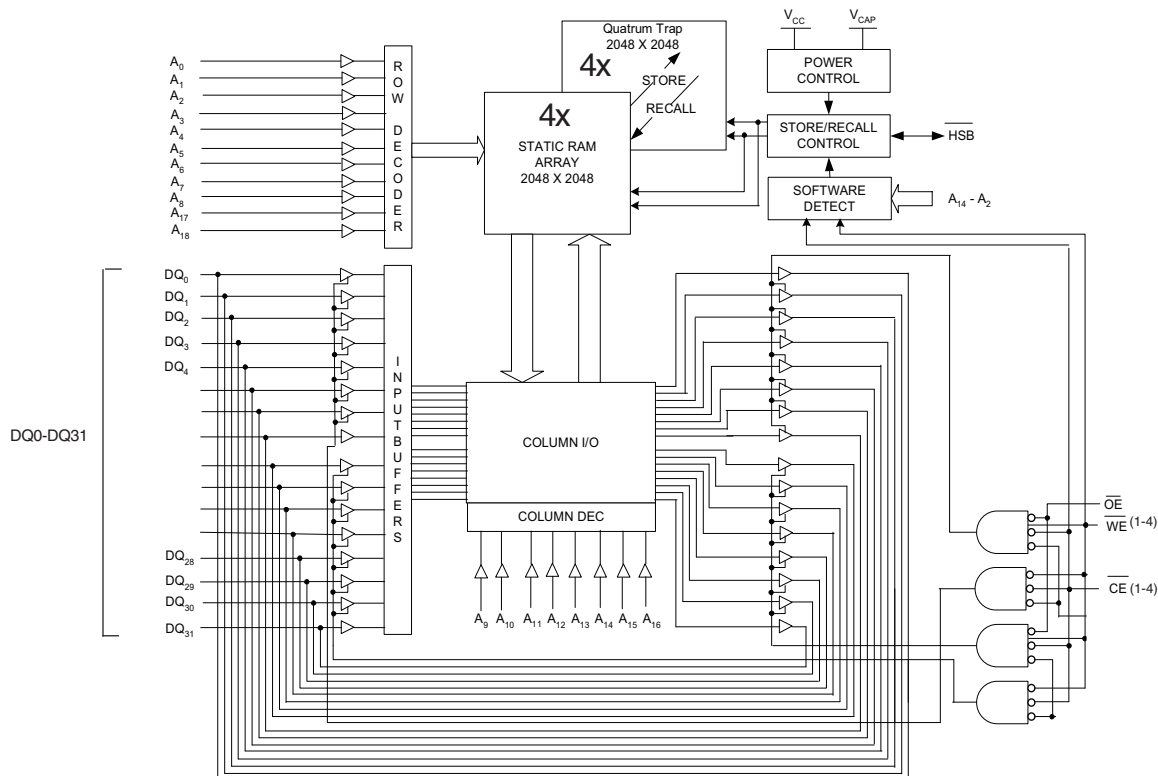



Device Operation

The AS8nvC512K32 nvSRAM is made up of two functional components paired in the same physical cell. They are a SRAM memory cell and a nonvolatile QuantumTrap cell. The SRAM memory cell operates as a standard fast static RAM. Data in the SRAM is transferred to the nonvolatile cell (the STORE operation), or from the nonvolatile cell to the SRAM (the RECALL operation). Using this unique architecture, all cells are stored and recalled in parallel. During the STORE and RECALL operations, SRAM read and write operations are inhibited. The AS8nvC512K32 supports infinite reads and writes similar to a typical SRAM. In addition, it provides infinite RECALL operations from the nonvolatile cells and up to 200K STORE operations. See the Truth Table For SRAM Operations for a complete description of read and write modes.

SRAM Read

The AS8nvC512K32 performs a read cycle when CE\ and OE\ are LOW and WE\ and HSB\ are HIGH. The address specified on pins A0-18 determines which of the 524,288 data bytes. When the read is initiated by an address transition, the outputs are valid after a delay of t_{AA} (read cycle 1). If the read is initiated by CE\ or OE\, the outputs are valid at t_{ACE} or at t_{DOE} , whichever is later (read cycle 2). The data output repeatedly responds to address changes within the t_{AA} access time without the need for transitions on any control input pins. This remains valid until another address change or until CE\ or OE\ is brought HIGH, or WE\ or HSB\ is brought LOW.

SRAM Write

A write cycle is performed when CE\ and WE\ are LOW and HSB\ is HIGH. The address inputs must be stable before entering the write cycle and must remain stable until CE\ or WE\ goes HIGH at the end of the cycle. The data on the common I/O pins DQ0-31 are written into the memory if the data is valid t_{SD} before the end of a WE\ controlled write or before the end of an CE\ controlled write. It is recommended that OE\ be kept HIGH during the entire write cycle to avoid data bus contention on common I/O lines. If OE\ is left LOW, internal circuitry turns off the output buffers tHZWE after WE\ goes LOW.

AutoStore Operation

The AS8nvC512K32 stores data to the nvSRAM using one of the following three storage operations: Hardware Store activated by HSB\; Software Store activated by an address sequence; AutoStore on device power down. The AutoStore operation is a unique feature of QuantumTrap technology and is enabled by default on the AS8nvC512K32.

During a normal operation, the device draws current from V_{CC} to charge a capacitor connected to the V_{CAP} pin. This stored charge is used by the chip to perform a single STORE operation. If the voltage on the V_{CC} pin drops below V_{SWITCH} , the part automatically disconnects the V_{CAP} pin from V_{CC} . A STORE operation is initiated with power provided by the V_{CAP} capacitor.

Figure 2 shows the proper connection of the storage capacitor (V_{CAP})

for automatic store operation. Refer to DC Electrical Characteristics for the size of V_{CAP} . The voltage on the V_{CAP} pin is driven to V_{CC} by a regulator on the chip. A pull up should be placed on WE\ to hold it inactive during power up. This pull up is effective only if the WE\ signal is tri-state during power up. Many MPUs tri-state their controls on power up. This should be verified when using the pull up. When the nvSRAM comes out of power-on-recall, the MPU must be active or the WE\ held inactive until the MPU comes out of reset.

To reduce unnecessary nonvolatile stores, AutoStore and hardware store operations are ignored unless at least one write operation has taken place since the most recent STORE or RECALL cycle. Software initiated STORE cycles are performed regardless of whether a write operation has taken place. The HSB\ signal is monitored by the system to detect if an AutoStore cycle is in progress.

Figure 2. AutoStore Mode

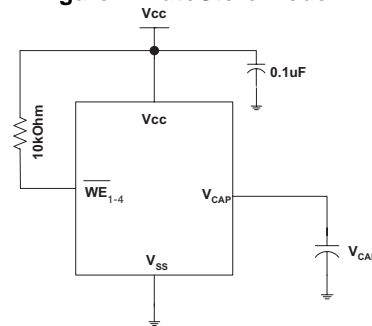

Hardware STORE Operation

The AS8nvC512K32 provides the HSB\ pin to control and acknowledge the STORE operations. Use the HSB\ pin to request a hardware STORE cycle. When the HSB pin is driven LOW, the AS8nvC512K32 conditionally initiates a STORE operation after t_{DELAY} . An actual STORE cycle only begins if a write to the SRAM has taken place since the last STORE or RECALL cycle. The HSB\ pin also acts as an open drain driver that is internally driven LOW to indicate a busy condition when the STORE (initiated by any means) is in progress.

SRAM read and write operations that are in progress when HSB is driven LOW by any means are given time to complete before the STORE operation is initiated. After HSB\ goes LOW, the AS8nvC512K32 continues SRAM operations for t_{DELAY} . If a write is in progress when HSB\ is pulled LOW it is enabled a time, t_{DELAY} to complete. However, any SRAM write cycles requested after HSB\ goes LOW are inhibited until HSB\ returns HIGH. In case the write latch is not set, HSB\ is not driven LOW by the AS8nvC512K32. But any SRAM read and write cycles are inhibited until HSB\ is returned HIGH by MPU or other external source.

During any STORE operation, regardless of how it is initiated, the AS8nvC512K32 continues to drive the HSB\ pin LOW, releasing it only when the STORE is complete. When the STORE operation is completed, the AS8nvC512K32 remains disabled until the HSB\ pin returns HIGH. Leave the HSB\ unconnected if it is not used..



Hardware RECALL (Power Up)

During power up or after any low power condition ($VCC < VSWITCH$), an internal RECALL request is latched. When VCC again exceeds the sense voltage of VSWITCH, a RECALL cycle is automatically initiated and takes tHRECALL to complete. During this time, HSB is driven LOW by the HSB driver.

Software STORE

Transfer data from the SRAM to the nonvolatile memory with a software address sequence. The AS8nvC512K32 software STORE cycle is initiated by executing sequential CE controlled read cycles from six specific address locations in exact order. During the STORE cycle an erase of the previous nonvolatile data is first performed, followed by a program of the nonvolatile elements. After a STORE cycle is initiated, further input and output are disabled until the cycle is completed.

Because a sequence of READs from specific addresses is used for STORE initiation, it is important that no other read or write accesses intervene in the sequence, or the sequence is aborted and no STORE or RECALL takes place.

To initiate the software STORE cycle, the following read sequence must be performed.

1. Read Address 0x4E38 Valid READ
2. Read Address 0xB1C7 Valid READ
3. Read Address 0x83E0 Valid READ
4. Read Address 0x7C1F Valid READ
5. Read Address 0x703F Valid READ
6. Read Address 0x8FC0 Initiate STORE Cycle

The software sequence may be clocked with CE controlled reads or OE controlled reads. After the sixth address in the sequence is entered, the STORE cycle commences and the chip is disabled. HSB is driven LOW. It is important to use read cycles and not write cycles in the sequence, although it is not necessary that OE be LOW for a valid sequence. After the tSTORE cycle time is fulfilled, the SRAM is activated again for the read and write operation.

Software RECALL

Transfer the data from the nonvolatile memory to the SRAM with a software address sequence. A software RECALL cycle is initiated with a sequence of read operations in a manner similar to the software STORE initiation. To initiate the RECALL cycle, the following sequence of CE controlled read operations must be performed.

1. Read Address 0x4E38 Valid READ
2. Read Address 0xB1C7 Valid READ
3. Read Address 0x83E0 Valid READ
4. Read Address 0x7C1F Valid READ
5. Read Address 0x703F Valid READ
6. Read Address 0x4C63 Initiate RECALL Cycle

Internally, RECALL is a two step procedure. First, the SRAM data is cleared; then, the nonvolatile information is transferred into the SRAM cells. After the tRECALL cycle time, the SRAM is again ready for read and write operations. The RECALL operation does not alter the data in the nonvolatile elements.

Mode Selection

CE _{\1-4}	WE _{\1-4}	OE ¹³	A15-A0 ⁷	Mode	I/O ₀₋₃₁	Power
H	X	X	X	Not Selected	Output High Z	Standby
L	H	L	X	Read SRAM	Output Data	Active
L	L	X	X	Write SRAM	Input Data	Active
L	H	L	0x4E38 0xB1C7 0x83E0 0x7C1F 0x703F 0x8B45	Read SRAM Read SRAM Read SRAM Read SRAM Read SRAM AutoStore Disable	Output Data Output Data Output Data Output Data Output Data Output Data	Active ⁸

Notes

7. While there are 19 address lines on the AS8nvC512K32, only the 13 address lines (A14 - A2) are used to control software modes. Rest of the address lines are don't care.

8. The six consecutive address locations must be in the order listed. WE must be HIGH during all six cycles to enable a nonvolatile cycle.

13. WE_\ must be HIGH during SRAM read cycles.



Mode Selection (continued)

CE\ ₁₋₄	WE\ ₁₋₄	OE\ ¹³	A15-A0 ⁷	Mode	I/O ₀₋₃₁	Power
L	H	L	0x4E38 0xB1C7 0x83E0 0x7C1F 0x703F 0x4B46	Read SRAM Read SRAM Read SRAM Read SRAM Read SRAM AutoStore Enable	Output Data Output Data Output Data Output Data Output Data Output Data	Active ⁸
L	H	L	0x4E38 0xB1C7 0x83E0 0x7C1F 0x703F 0x8FC0	Read SRAM Read SRAM Read SRAM Read SRAM Read SRAM Nonvolatile Store	Output Data Output Data Output Data Output Data Output Data Output High Z	Active I _{CC2} ⁸
L	H	L	0x4E38 0xB1C7 0x83E0 0x7C1F 0x703F 0x4C63	Read SRAM Read SRAM Read SRAM Read SRAM Read SRAM Nonvolatile Recall	Output Data Output Data Output Data Output Data Output Data Output High Z	Active ⁸

Preventing AutoStore

The AutoStore function is disabled by initiating an AutoStore disable sequence. A sequence of read operations is performed in a manner similar to the software STORE initiation. To initiate the AutoStore disable sequence, the following sequence of CE controlled read operations must be performed:

1. Read address 0x4E38 Valid READ
2. Read address 0xB1C7 Valid READ
3. Read address 0x83E0 Valid READ
4. Read address 0x7C1F Valid READ
5. Read address 0x703F Valid READ
6. Read address 0x8B45 AutoStore Disable

The AutoStore is re-enabled by initiating an AutoStore enable sequence. A sequence of read operations is performed in a manner similar to the software RECALL initiation. To initiate the AutoStore enable sequence, the following sequence of CE controlled read operations must be performed:

1. Read address 0x4E38 Valid READ
2. Read address 0xB1C7 Valid READ
3. Read address 0x83E0 Valid READ
4. Read address 0x7C1F Valid READ
5. Read address 0x703F Valid READ
6. Read address 0x4B46 AutoStore Enable

If the AutoStore function is disabled or re-enabled, a manual STORE operation (hardware or software) must be issued to save the AutoStore state through subsequent power down cycles. The part comes from the factory with AutoStore enabled.

Data Protection

The AS8nvC512K32 protects data from corruption during low voltage conditions by inhibiting all externally initiated STORE and write operations. The low voltage condition is detected when VCC < VSWITCH. If the AS8nvC512K32 is in a write mode (both CE and WE are LOW) at power up, after a RECALL or STORE, the write is inhibited until the SRAM is enabled after tLZHSB (HSB to output active). This protects against inadvertent writes during power up or brown out conditions.



Best Practices

nvSRAM products have been used effectively for over 15 years. While ease-of-use is one of the product's main system values, experience gained working with hundreds of applications has resulted in the following suggestions as best practices:

- The nonvolatile cells in this nvSRAM product are delivered from Microcross Components with 0x00 written in all cells. Incoming inspection routines at customer or contract manufacturer's sites sometimes reprogram these values. Final NV patterns are typically repeating patterns of AA, 55, 00, FF, A5, or 5A. End product's firmware should not assume an NV array is in a set programmed state. Routines that check memory content values to determine first time system configuration, cold or warm boot status, and so on should always program a unique NV pattern (that is, complex 4-byte pattern of 46 E6 49 53 hex or more random bytes) as part of the final system manufacturing test to ensure these system routines work consistently.
- Power up boot firmware routines should rewrite the nvSRAM into the desired state (for example, autostore enabled). While the nvSRAM is shipped in a preset state, best practice is to again rewrite the nvSRAM into the desired state as a safeguard against events that might flip the bit inadvertently such as program bugs and incoming inspection routines.
- The VCAP value specified in this data sheet includes a minimum and a maximum value size. Best practice is to meet this requirement and not exceed the maximum VCAP value because the nvSRAM internal algorithm calculates VCAP charge and discharge time based on this max VCAP value. Customers that want to use a larger VCAP value to make sure there is extra store charge and store time should discuss their VCAP size selection with Microcross Components to understand any impact on the VCAP voltage level at the end of a T_{RECALL} period.



Maximum Ratings

Exceeding maximum ratings may impair the useful life of the device. These user guidelines are not tested.

Storage Temperature-65°C to +150°C

Maximum Accumulated Storage Time
At 150°C Ambient Temperature.....1000h
At 85°C Ambient Temperature.....20 Years

Ambient Temperature with Power Applied-55°C to +125°C

Supply Voltage on V_{CC} Relative to GND..... -0.5V to 6.0V

Voltage Applied to Outputs in High-Z State -0.5V to V_{CC} + 0.5V

Input Voltage -0.5V to V_{CC} + 0.5V

Transient Voltage (<20 ns) on

Any Pin to Ground Potential.....-2.0V to V_{CC} + 2.0V

Package Power Dissipation Capability (TA = 25°C)1.0W

Surface Mount Pb Soldering Temperature (3 Seconds).....+260°C

DC Output Current (1 output at a time, 1s duration)15 mA

Static Discharge Voltage > 2001V (per MIL-STD-883, Method 3015)

Latch Up Current..... > 200 mA

Operating Range

Range	Ambient Temperature	V _{CC}
Military	-55°C to +125°C	5.0V ±10%
Enhanced	-40°C to +105°C	5.0V ±10%
Industrial	-40°C to +85°C	5.0V ±10%

DC Electrical Characteristics

Over the Operating Range (V_{CC} = 5.0V ±10%)

Parameter	Description	Test Conditions	Min	Max	Unit
I _{CC1}	Average V _{CC} Current	t _{RC} = 20 ns t _{RC} = 25 ns t _{RC} = 45 ns Values obtained without output loads (I _{OUT} = 0 mA)			
I _{CC2}	Average V _{CC} Current during STORE	All Inputs Don't Care, V _{CC} = Max Average current for duration t _{STORE}		60	mA
I _{CC3} ⁹	Average V _{CC} Current at t _{RC} = 200 ns, 5V, 25°C typical	All I/P cycling at CMOS levels. Values obtained without output loads (I _{OUT} = 0 mA).		220	mA
I _{CC4}	Average V _{CAP} Current during AutoStore Cycle	All Inputs Don't Care, V _{CC} = Max Average current for duration t _{STORE}		40	mA
I _{SB}	V _{CC} Standby Current	CE \(\geq (V_{CC} - 0.2V)\). All others V _{IN} \(\leq 0.2V\) or \(\geq (V_{CC} - 0.2V)\). Standby current level after nonvolatile cycle is complete. Inputs are static. f = 0 MHz.		40	mA
I _{IX} ¹⁰	Input Leakage Current (except HSB\)	V _{CC} = Max, V _{SS} \(\leq V_{IN} \leq V_{CC}\)	-5	5	\(\mu A\)
	Input Leakage Current (for HSB\)	V _{CC} = Max, V _{SS} \(\leq V_{IN} \leq V_{CC}\)	-400	10	\(\mu A\)
I _{OZ}	Off-State Output Leakage Current	V _{CC} = Max, V _{SS} \(\leq V_{OUT} \leq V_{CC}\), CE\ or OE\ \(\geq V_{IH}\) or BHE\ or BLE\ \(\geq V_{IH}\) or WE\ \(\leq V_{IL}\)	-10	10	\(\mu A\)
V _{IH}	Input HIGH Voltage		2.2	V _{CC} + 0.3	V
V _{IL}	Input LOW Voltage		V _{SS} - 0.3	0.8	V
V _{OH}	Output HIGH Voltage	I _{OUT} = -2 mA	2.4		V
V _{OL}	Output LOW Voltage	I _{OUT} = 4 mA		0.45	V
V _{CAP}	Storage Capacitor	Between V _{CAP} pin and V _{SS} , 10.0V Rated	80	180	\(\mu F\)

Notes

- 9. Typical conditions for the active current shown on the DC Electrical characteristics are average values at 25°C (room temperature), and V_{CC} = 5V. Not 100% tested.
- 10. The HSB\ pin has I_{OUT} = -8 \(\mu A\) for V_{OH} of 2.4V when both active HIGH and LOW drivers are disabled. When they are enabled standard V_{OH} and V_{OL} are valid. This parameter is characterized but not tested.



Data Retention and Endurance

Parameter	Description	Min	Unit
DATA _R	Data Retention	20	Years
NV _C	Nonvolatile STORE Operation	200	Cycles

Capacitance

In the following table, the capacitance parameters are listed. ¹²

Parameter	Description	Test Conditions	Min	Unit
C _{IN}	Input Capacitance (Addr, OE\, HSB\) x 4	T _A = 25°C, f = 1 MHz, V _{CC} = 0 to 3.0V	50	pF
C _{IN}	Input Capacitance (CE\ ₁₋₄ , WE\ ₁₋₄ x 1		20	pF
C _{OUT(DQ)}	I/O Capacitance x 1		25	pF

Thermal Resistance

In the following table, the thermal resistance parameters are listed. ¹²

Parameter	Description	Test Conditions	68-CQFP	Unit
Θ _{JC}	Thermal Resistance (Junction to Case)	Test conditions follow standard test methods and procedures for measuring thermal impedance, in accordance with EIA/JESD51.	11.3	°C/W

AC Test Loads

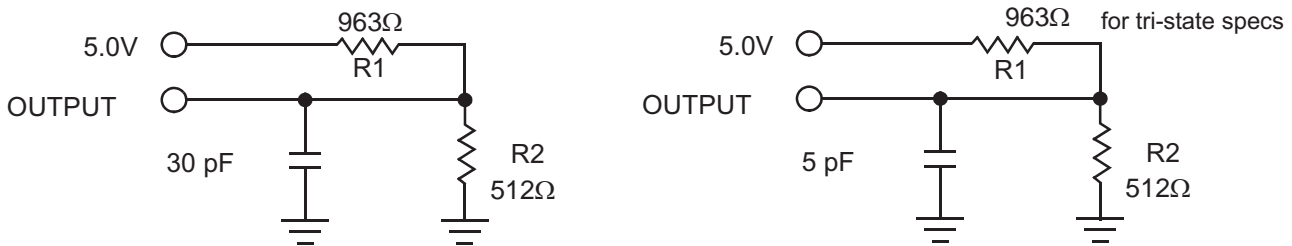

AC Test Conditions

Input Pulse Levels0V to 3V
 Input Rise and Fall Times (10% - 90%)..... <3 ns
 Input and Output Timing Reference Levels 1.5V

Note

12. These parameters are guaranteed by design but not tested.



AC Switching Characteristics

Parameters		Description	20 ns		25 ns		45 ns		Unit
Micross Parameters	Alt Parameters		Min	Max	Min	Max	Min	Max	
SRAM Read Cycle									
t_{ACE}	t_{ACS}	Chip Enable Access Time		20		25		45	ns
t_{RC}^{13}	t_{RC}	Read Cycle Time	20		25		45		ns
t_{AA}^{14}	t_{AA}	Address Access Time		20		25		45	ns
t_{DOE}	t_{OE}	Output Enable to Data Valid		10		12		20	ns
t_{OHA}^{14}	t_{OH}	Output Hold After Address Change	2		2		2		ns
$t_{LZCE}^{12,15}$	t_{LZ}	Chip Enable to Output Active	2		2		2		ns
$t_{HZCE}^{12,15}$	t_{HZ}	Chip Disable to Output Active		8		10		15	ns
$t_{LZOE}^{12,15}$	t_{OLZ}	Output Enable to Output Active	0		0		0		ns
$t_{HZOE}^{12,15}$	t_{OHZ}	Output Disable to Output Inactive		8		10		15	ns
t_{PU}^{12}	t_{PA}	Chip Enable to Power Active	0		0		0		ns
t_{PD}^{12}	t_{PS}	Chip Disable to Power Standby		20		25		45	ns
t_{DBE}	-	Byte Enable to Data Valid		10		12		20	ns
t_{LZBE}^{12}	-	Byte Enable to Output Active	0		0		0		ns
t_{HZBE}^{12}	-	Byte Disable to Output Inactive		8		10		15	ns
SRAM Write Cycle									
t_{WC}	t_{WC}	Write Cycle Time	20		25		45		ns
t_{PWE}	t_{WP}	Write Pulse Width	15		20		30		ns
t_{SCE}	t_{CW}	Chip Enable to End of Write	15		20		30		ns
t_{SD}	t_{DW}	Data Setup to End of Write	8		10		15		ns
t_{HD}	t_{DH}	Data Hold After End of Write	0		0		0		ns
t_{AW}	t_{AW}	Address Setup to End of Write	15		20		30		ns
t_{SA}	t_{AS}	Address Setup to End of Write	0		0		0		ns
t_{HA}	t_{WR}	Address Hold After End of Write	0		0		0		ns
$t_{HZWE}^{12,15,16}$	t_{WZ}	Write Enable to Output Disable		8		10		15	ns
$t_{LZWE}^{12,15}$	t_{OW}	Output Active after End of Write	2		2		2		ns
t_{BW}	-	Byte Enable to End of Write	15		20		30		ns

Switching Waveforms

SRAM Read Cycle #1: Address Controlled ^{13, 14, 17}

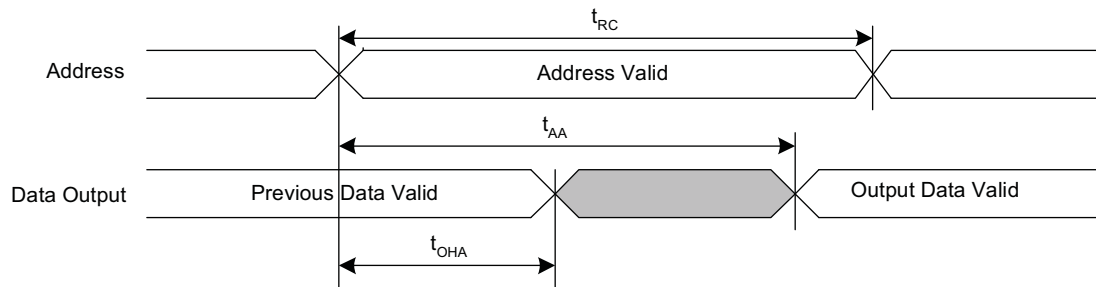

Notes

- 13. WE\ must be HIGH during SRAM read cycles.
- 14. Device is continuously selected with CE\, OE\ LOW.
- 15. Measured ± 200 mV from steady state output voltage.
- 16. If WE\ is LOW when CE\ goes LOW, the outputs remain in the high impedance state.
- 17. HSB\ must remain HIGH during read and write cycles.



SRAM Read Cycle #2: CE\ and OE\ Controlled^{3, 13, 17}

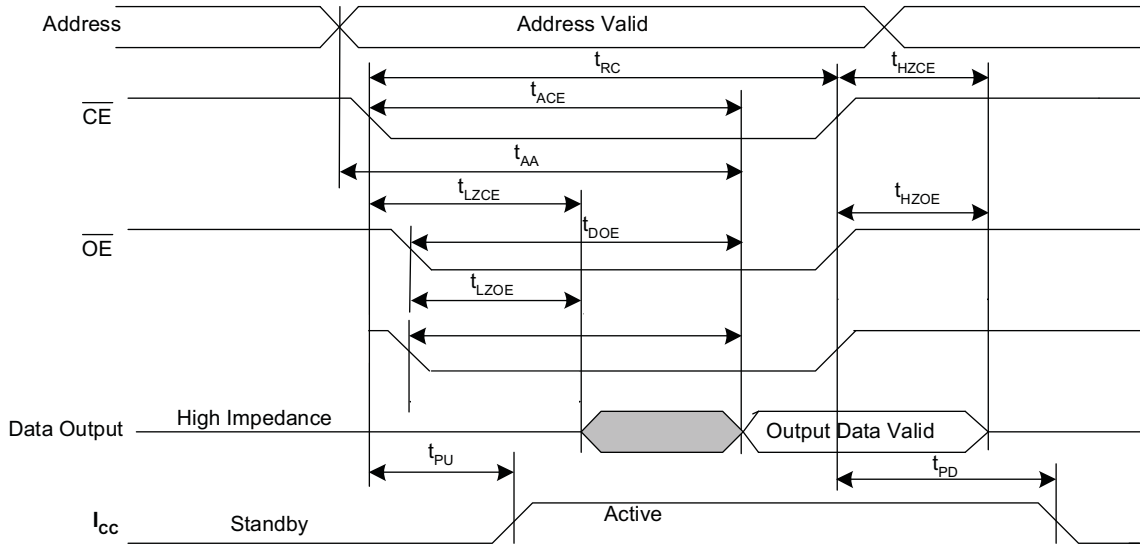

SRAM Write Cycle #1: WE\ Controlled^{3, 16, 17, 18}

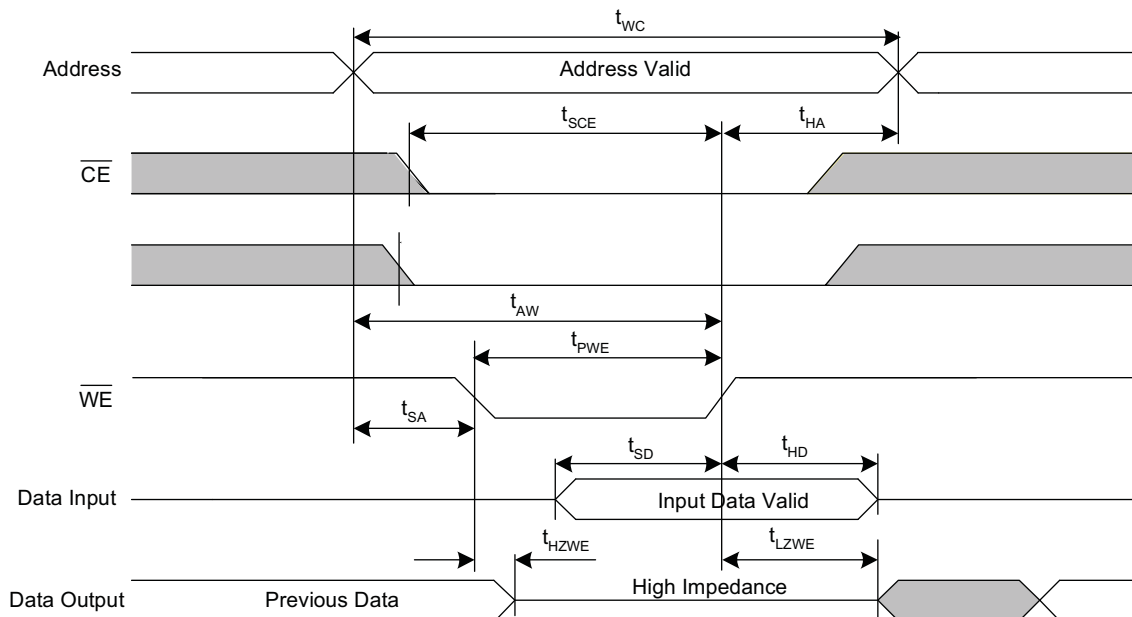

Note
18. CE\ or WE\ must be $>V_{IH}$ during address transitions.



SRAM Write Cycle #2: CE\ Controlled^{3, 16, 17, 18}

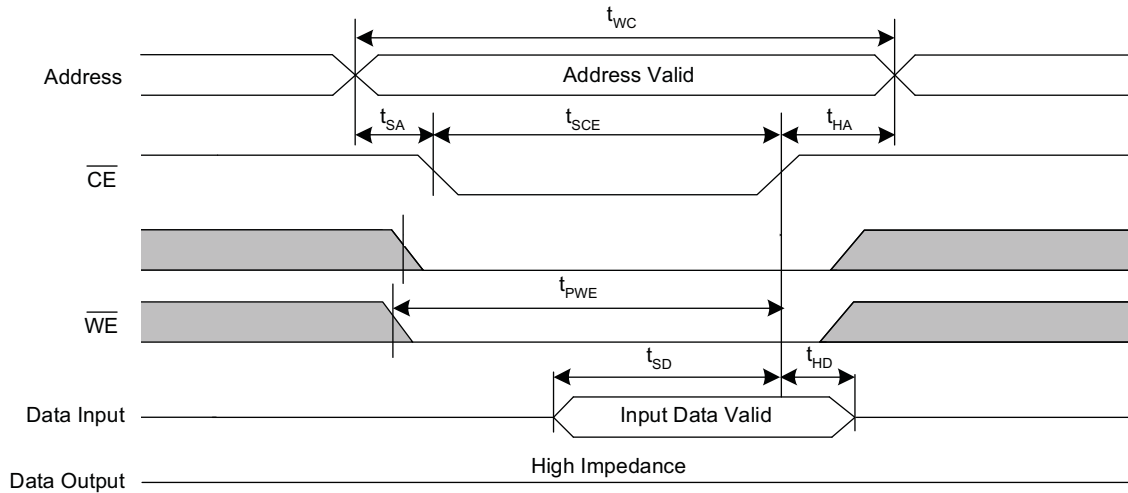



AutoStore/Power Up RECALL

Parameters	Description	20 ns		25 ns		45 ns		Unit
		Min	Max	Min	Max	Min	Max	
$t_{HRECALL}^{19}$	Power Up RECALL Duration		20		20		20	ms
t_{STORE}^{20}	STORE Cycle Duration		10		10		10	ms
t_{DELAY}^{21}	Time Allowed to Complete SRAM Cycle		20		25		25	ns
V_{SWITCH}	Low Voltage Trigger Level		3.65		3.65		3.65	V
$t_{VCCRRISE}^{12}$	VCC Rise Time	150		150		150		μ s
V_{HDIS}^{12}	HSB\ Output Driver Disable Voltage		1.9		1.9		1.9	V
t_{LZHHSB}^{12}	HSB\ To Output Active Time		5		5		5	μ s
t_{HHHD}^{12}	HSB\ High Active Time		500		500		500	ns

Switching Waveforms

AutoStore or Power Up RECALL²²

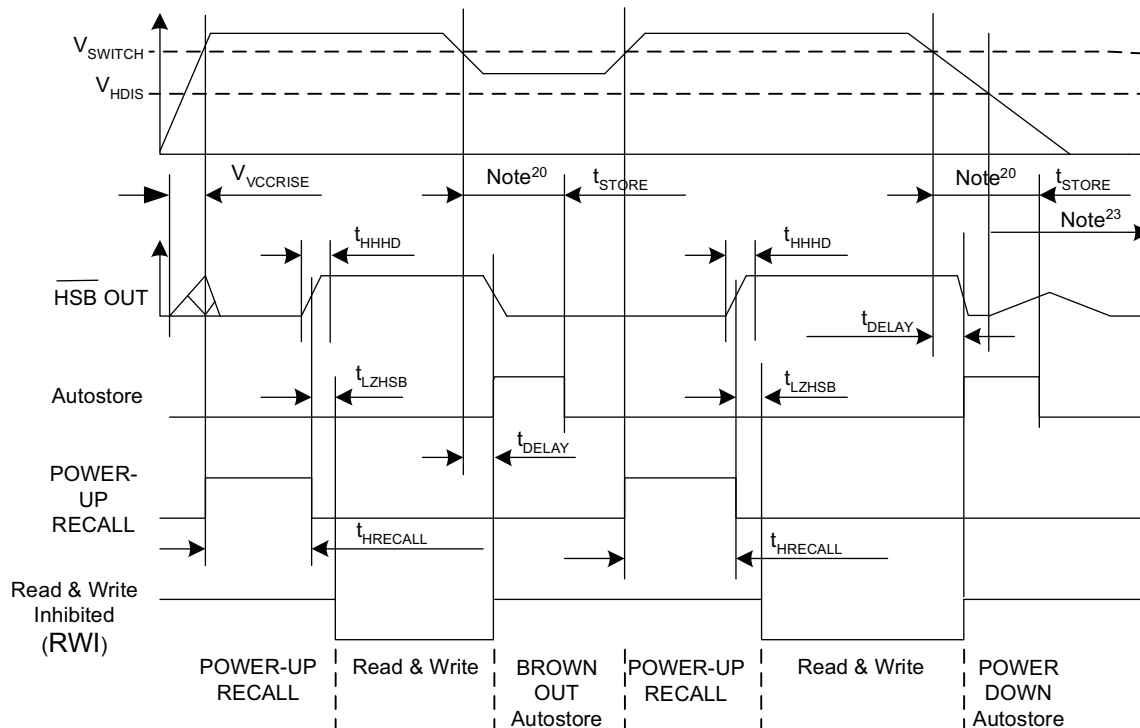

Notes

- 19. $t_{HRECALL}$ starts from the time VCC rises above V_{SWITCH} .
- 20. If an SRAM write has not taken place since the last nonvolatile cycle, no AutoStore or Hardware Store takes place.
- 21. On a Hardware STORE, Software Store / Recall, AutoStore Enable / Disable and AutoStore initiation, SRAM operation continues to be enabled for time t_{DELAY} .
- 22. Read and write cycles are ignored during STORE, RECALL, and while VCC is below V_{SWITCH} .
- 23. HSB\ pin is driven HIGH to VCC only by internal 100 kOhm resistor, HSB\ driver is disabled.



Software Controlled STORE/RECALL Cycle

In the following table, the software controlled STORE and RECALL cycle parameters are listed.^{24,25}

Parameters	Description	20 ns		25 ns		45 ns		Unit
		Min	Max	Min	Max	Min	Max	
t_{RC}	STORE/RECALL Initiation Cycle Time	20		25		45		ns
t_{SA}	Address Setup Time	0		0		0		ns
t_{CW}	Clock Pulse Width	15		25		30		ns
t_{HA}	Address Hold Time	0		0		0		ns
t_{RECALL}	RECALL Duration		200		200		200	μ s

Switching Waveforms

CE\ and OE \Controlled Software STORE/RECALL Cycle²⁵

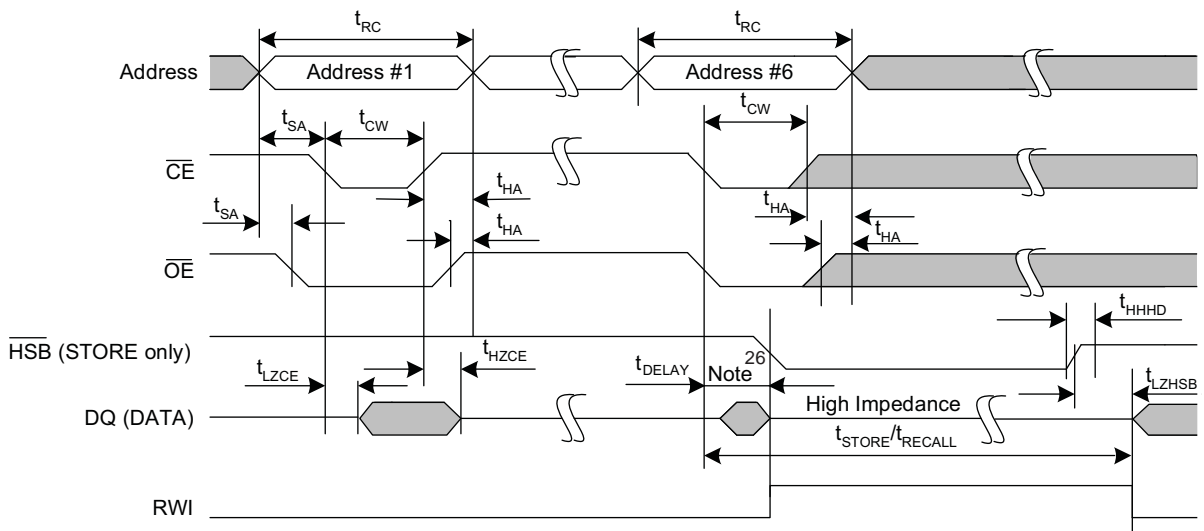
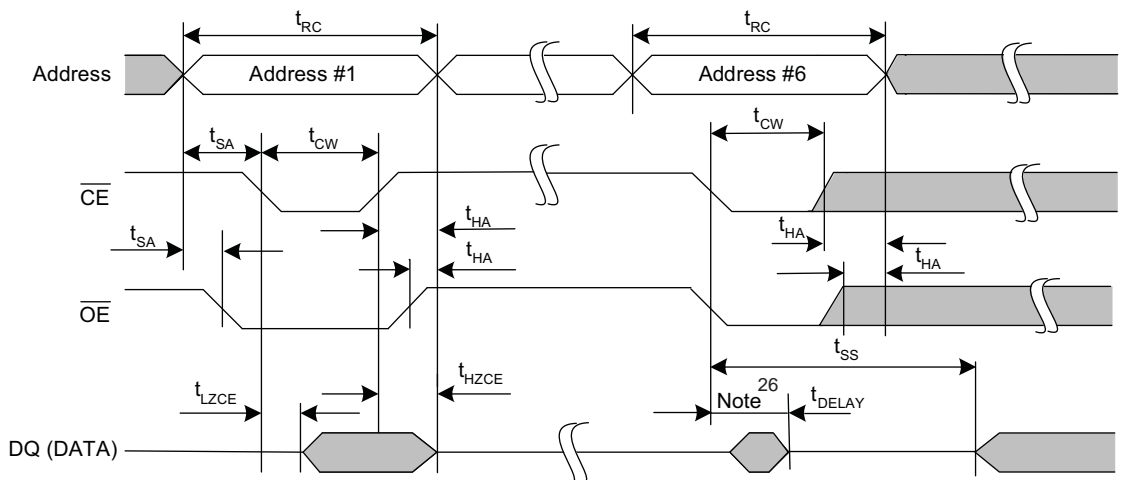

Figure 13. AutoStore Enable/Disable Cycle



Notes

24. The software sequence is clocked with CE\ controlled or OE\ controlled reads.

25. The six consecutive addresses must be read in the order listed in the Mode Selection Table. WE\ must be HIGH during all six consecutive cycles.

26. DQ output data at the sixth read may be invalid since the output is disabled at t_{DELAY} time.



Hardware STORE Cycle

Parameters	Description	20 ns		25 ns		45 ns		Unit
		Min	Max	Min	Max	Min	Max	
t_{DHSB}	HSB\ to Output Active Time when latch not set		20		25		25	ns
t_{PHSB}	Hardware STORE Pulse Width	15		15		15		ns
$t_{SS}^{27,28}$	Soft Sequence Processing Time		100		100		100	μ s

Switching Waveforms

Hardware STORE Cycle¹⁹

Write latch set

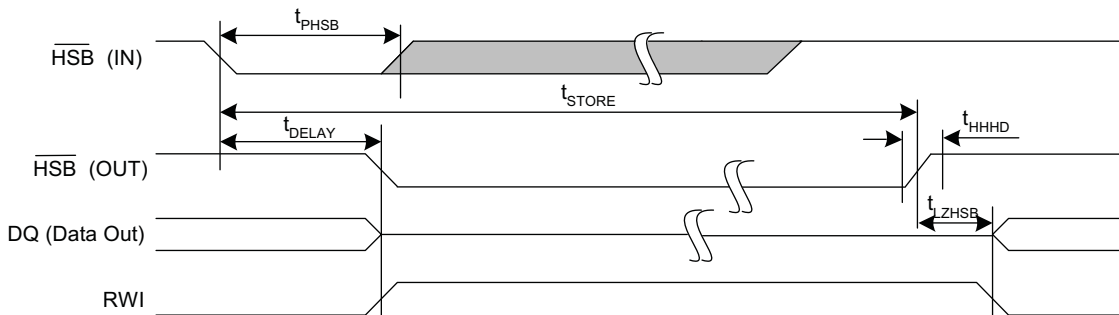

Write latch not set

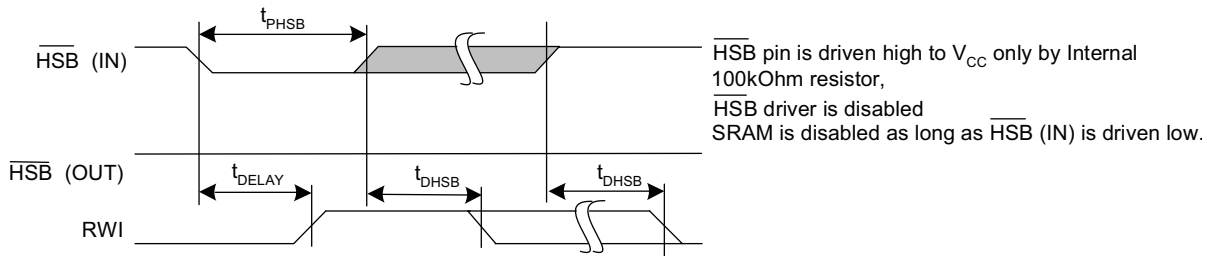

Soft Sequence Processing^{27,28}

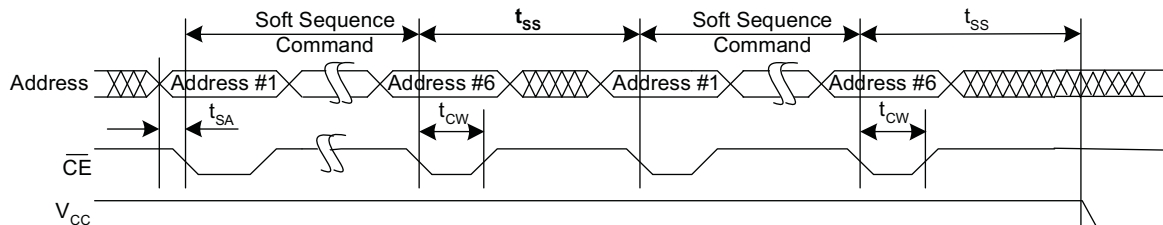

Notes

- 27. This is the amount of time it takes to take action on a soft sequence command. Vcc power must remain HIGH to effectively register command.
- 28. Commands such as STORE and RECALL lock out I/O until operation is complete which further increases this time. See the specific command.



Truth Table For SRAM Operations

HSB\ should remain HIGH for SRAM Operations.

For x32 Configuration

CE\ ₁₋₄	WE\ ₁₋₄	OE\	Inputs / Outputs	Mode	Power
H	X	X	High Z	Deselect / Power Down	Standby
L	H	L	Data Out (DQ0-DQ31)	Read	Active
L	H	H	High Z	Output Disabled	Active
L	L	X	Data In (DQ0-DQ31)	Write	Active



Ceramic 68 Quad Flat Pack

Microcross Package Designator Q

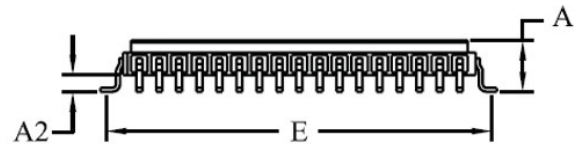
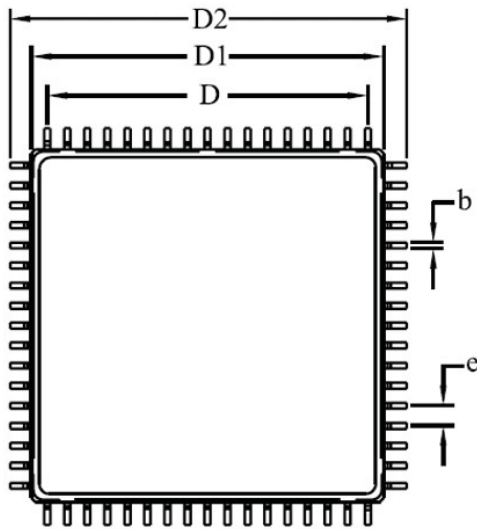

PACKAGE SPECIFICATION		
Symbol	Min	Max
A	.135	.155
A2	.005	.020
B	.010 REF	
b	.013	.017
D	.800 BSC	
D1	.870	.890
D2	.980	1.000
E	.936	.956
e	.050 BSC	
R	.010 TYP	
L1	.035	.045
Dimensions in inches		

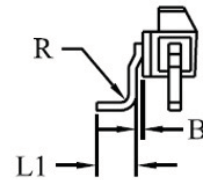



Ceramic 68 Quad Flat Pack

Micross Package Designator QB

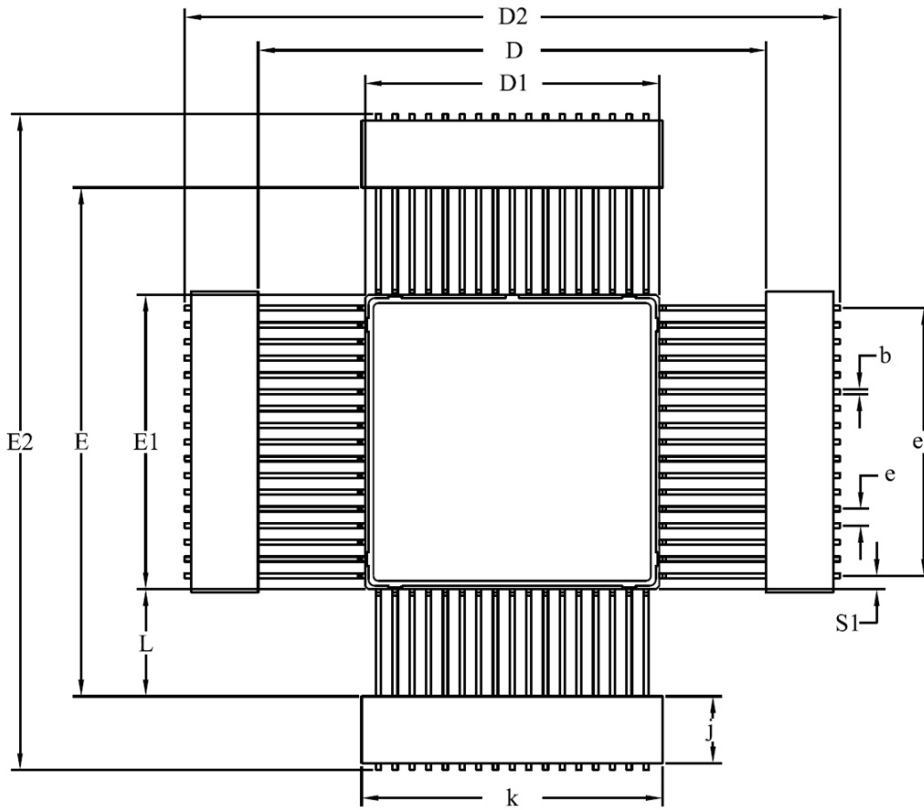

PACKAGE SPECIFICATION		
Symbol	Min	Max
A	.135	.155
A1	.115	.135
A2	.005	.020
b	.013	.017
c	.009	.012
D/E	1.500	1.540
D1/E1	.870	.890
D2/E2	1.920	2.000
e	.050 BSC	
e1	.800 BSC	
J	.190	.210
k	.890	.910
L	.310	.330
S1	.040 BSC	
Dimensions in inches		

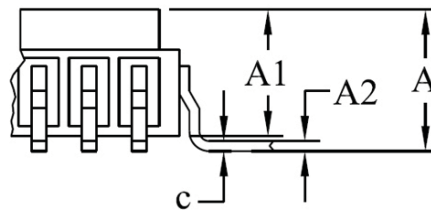
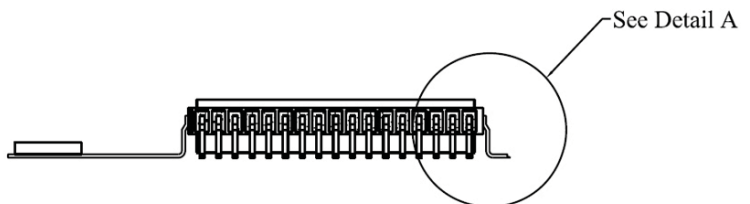

Detail A



Ordering Information

Microcross Part Number	Configuration	Package Type	Speed (ns)	Process
AS8nvC512K32QB-20/MIL	512K x 32	68 Quad Flat Pack w/ Tie-bar	20	MIL
AS8nvC512K32QB-25/MIL	512K x 32	68 Quad Flat Pack w/ Tie-bar	25	MIL
AS8nvC512K32QB-45/MIL	512K x 32	68 Quad Flat Pack w/ Tie-bar	45	MIL
AS8nvC512K32QB-20/XT	512K x 32	68 Quad Flat Pack w/ Tie-bar	20	XT
AS8nvC512K32QB-25/XT	512K x 32	68 Quad Flat Pack w/ Tie-bar	25	XT
AS8nvC512K32QB-45/XT	512K x 32	68 Quad Flat Pack w/ Tie-bar	45	XT
AS8nvC512K32QB-20/ET	512K x 32	68 Quad Flat Pack w/ Tie-bar	20	ET
AS8nvC512K32QB-25/ET	512K x 32	68 Quad Flat Pack w/ Tie-bar	25	ET
AS8nvC512K32QB-45/ET	512K x 32	68 Quad Flat Pack w/ Tie-bar	45	ET
AS8nvC512K32QB-20/IT	512K x 32	68 Quad Flat Pack w/ Tie-bar	20	IT
AS8nvC512K32QB-25/IT	512K x 32	68 Quad Flat Pack w/ Tie-bar	25	IT
AS8nvC512K32QB-45/IT	512K x 32	68 Quad Flat Pack w/ Tie-bar	45	IT
AS8nvC512K32Q-20/MIL	512K x 32	68 Quad Flat Pack	20	MIL
AS8nvC512K32Q-25/MIL	512K x 32	68 Quad Flat Pack	25	MIL
AS8nvC512K32Q-45/MIL	512K x 32	68 Quad Flat Pack	45	MIL
AS8nvC512K32Q-20/XT	512K x 32	68 Quad Flat Pack	20	XT
AS8nvC512K32Q-25/XT	512K x 32	68 Quad Flat Pack	25	XT
AS8nvC512K32Q-45/XT	512K x 32	68 Quad Flat Pack	45	XT
AS8nvC512K32Q-20/ET	512K x 32	68 Quad Flat Pack	20	ET
AS8nvC512K32Q-25/ET	512K x 32	68 Quad Flat Pack	25	ET
AS8nvC512K32Q-45/ET	512K x 32	68 Quad Flat Pack	45	ET
AS8nvC512K32QB-20/IT	512K x 32	68 Quad Flat Pack	20	IT
AS8nvC512K32QB-25/IT	512K x 32	68 Quad Flat Pack	25	IT
AS8nvC512K32QB-45/IT	512K x 32	68 Quad Flat Pack	45	IT

*** AVAILABLE PROCESSES**

IT = Industrial Temperature Range
 ET = Enhanced Temperature Range
 XT = Military Temperature Range
 MIL = Military Processing

TEMPERATURE

-40⁰C to +85⁰C
 -40⁰C to +105⁰C
 -55⁰C to +125⁰C
 -55⁰C to +125⁰C



DOCUMENT TITLE

512K x 32 nvSRAM 5.0V High Speed SRAM with Non-Volatile Storage

REVISION HISTORY

<u>Rev #</u>	<u>History</u>	<u>Release Date</u>	<u>Status</u>
0.0	Document Creation	August 2009	Advance
0.1	Updated Micross Information	January 2010	Advance
0.5	Added Q & QB Package; changes to pin description, DC Electrical, Capacitance, Thermal Resistance, AutoStore and order chart; updated diagrams on page 13, added diagrams and chart on page 14, added Enhanced temp on page 1 & 18, changed CS\ to CE\ on Pin Assignment and Pin Out on page 1, added MIL processing	April 2010	Advance