

128K x 8 EEPROM
EEPROM Memory

AVAILABLE AS MILITARY SPECIFICATIONS

- MIL-STD-883

FEATURES

- High speed: 150, 200, and 250ns
- Data Retention: 10 Years
- Low power dissipation, active current (20mW/MHz (TYP)), standby current (100µW(MAX))
- Single +5V (±10%) power supply
- Data Polling and Ready/Busy Signals
- Erase/Write Endurance (10,000 cycles in a page mode)
- Software Data protection Algorithm
- Data Protection Circuitry during power on/off
- Hardware Data Protection with RES pin
- Automatic Programming:
Automatic Page Write: 10ms (MAX)
128 Byte page size

OPTIONS

- Timing
 - 150ns access
 - 200ns access
 - 250ns access
- Packages
 - Ceramic Flat Pack
 - Radiation Shielded Ceramic FP*
 - Ceramic SOJ
 - Plastic SOP
- Operating Temperature Ranges
 - Military (-55°C to +125°C)
 - Industrial (-40°C to +85°C)

MARKINGS

-15	F	No. 306
-20	SF	No. 305
-25	DCJ	No. 508
	DG	
	XT	
	IT	

*NOTE: Package lid is connected to ground (Vss).

For more products and information
please visit our web site at
www.austinsemiconductor.com

PIN ASSIGNMENT
(Top View)

**32-Pin CFP (F & SF), 32-Pin CSOJ (DCJ),
32-Pin SOP (DG)**

RDY/BUSY\	1	32	Vcc
A16	2	31	A15
A14	3	30	RES\
A12	4	29	WE\
A7	5	28	A13
A6	6	27	A8
A5	7	26	A9
A4	8	25	A11
A3	9	24	OE\
A2	10	23	A10
A1	11	22	CE\
A0	12	21	I/O 7
I/O 0	13	20	I/O 6
I/O 1	14	19	I/O 5
I/O 2	15	18	I/O 4
Vss	16	17	I/O 3

GENERAL DESCRIPTION

The Austin Semiconductor, Inc. AS58C1001 is a 1 Megabit CMOS Electrically Erasable Programmable Read Only Memory (EEPROM) organized as 131, 072 x 8 bits. The AS58C1001 is capable of in system electrical Byte and Page reprogrammability.

The AS58C1001 achieves high speed access, low power consumption, and a high level of reliability by employing advanced MNOS memory technology and CMOS process and circuitry technology and CMOS process and circuitry technology.

This device has a 128-Byte Page Programming function to make its erase and write operations faster. The AS58C1001 features Data Polling and a Ready/Busy signal to indicate completion of erase and programming operations.

This EEPROM provides several levels of data protection. Hardware data protection is provided with the RES pin, in addition to noise protection on the WE signal and write inhibit during power on and off. Software data protection is implemented using JEDEC Optional Standard algorithm.

The AS58C1001 is designed for high reliability in the most demanding applications. Data retention is specified for 10 years and erase/write endurance is guaranteed to a minimum of 10,000 cycles in the Page Mode.

FUNCTIONAL BLOCK DIAGRAM

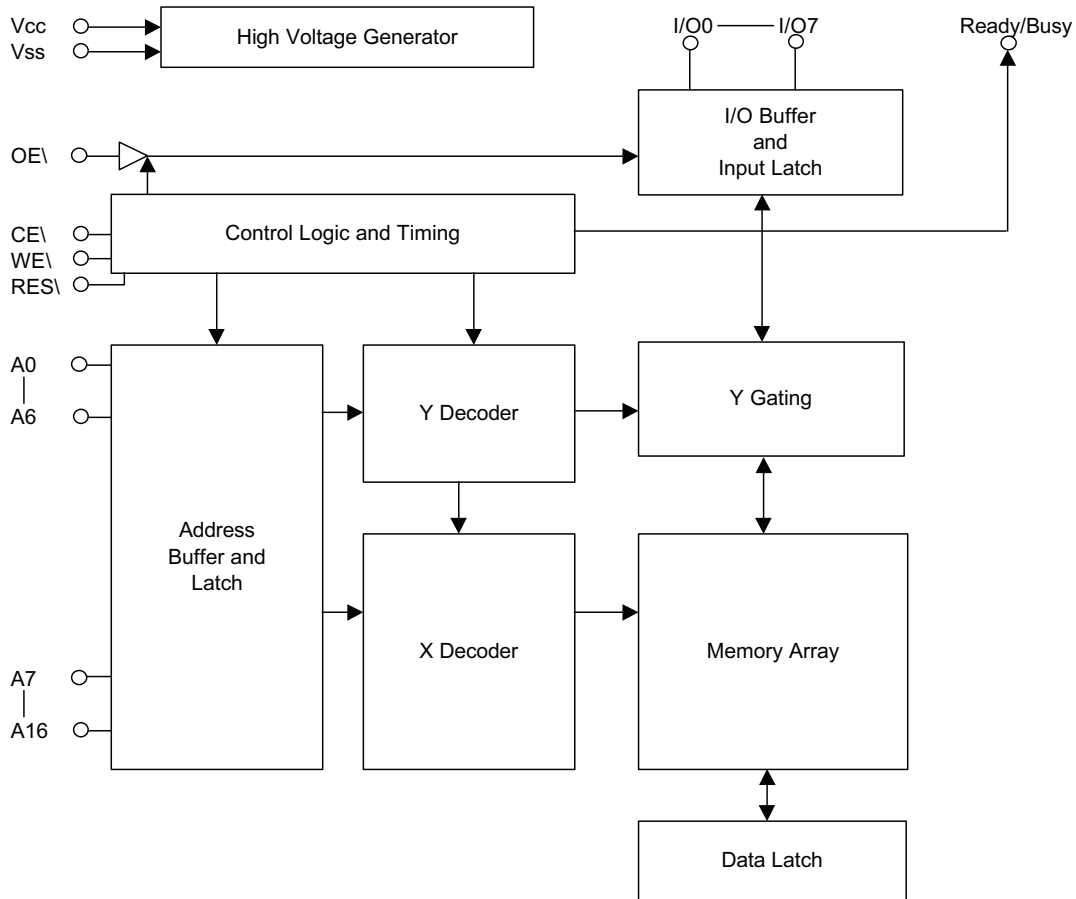

MODE SELECTION

MODE	CE\	OE\	WE\	RES\	RDY\BUSY\	I/O
READ	V _{IL}	V _{IL}	V _{IH}	V _H	High-Z	D _{OUT}
STANDBY	V _{IH}	X	X	X	High-Z	High-Z
WRITE	V _{IL}	V _{IH}	V _{IL}	V _H	High-Z	D _{IN}
DESELECT	V _{IL}	V _{IH}	V _{IH}	V _H	High-Z	High-Z
WRITE INHIBIT	X	X	V _{IH}	X	---	---
	X	V _{IL}	X	X	---	---
DATA POLLING	V _{IL}	V _{IL}	V _{IH}	V _H	V _{OL}	Data Out (I/O7)
PROGRAM	X	X	X	V _{IL}	High-Z	High-Z

FUNCTIONAL DESCRIPTION

AUTOMATIC PAGE WRITE

The Page Write feature allows 1 to 128 Bytes of data to be written into the EEPROM in a single cycle and allows the undefined data within 128 Bytes to be written corresponding to the undefined address (A_0 to A_6). Loading the first Byte of data, the data load window of 30 μ s opens for the second. In the same manner each additional Byte of data can be loaded within 30 μ s. In case \overline{CE} and \overline{WE} are kept high for 100 μ s after data input, the EEPROM enters erase and write automatically and only the input data can be written into the EEPROM. In Page mode the data can be written and accessed 10⁴ times per page, and in Byte mode 10³ times per Byte.

DATA POLLING

Data Polling allows the status of the EEPROM to be determined. If the EEPROM is set to Read mode during a Write cycle, and inversion of the last Byte of data to be loaded outputs from I/O, to indicate that the EEPROM is performing a Write operation.

WRITE PROTECTION

- (1) Noise protection: Noise on a write cycle will not act as a trigger with a \overline{WE} pulse of less than 20ns.
- (2) Write inhibit: Holding \overline{OE} low, \overline{WE} high or \overline{CE} high, inhibits a write cycle during power on/off.

\overline{WE} AND \overline{CE} PIN OPERATION

During a write cycle, addresses are latched by the falling edge of \overline{WE} or \overline{CE} , and data is latched by the rising edge of \overline{WE} or \overline{CE} .

WRITE/ERASE ENDURANCE AND DATA RETENTION

The endurance with page programming is 10⁴ cycles (1% cumulative failure rate) and the data retention time is more than 10 years when a device is programmed less than 10⁴ cycles.

DATA PROTECTION

To protect the data during operation and power on/off, the AS58C1001 has:

- 1. Data protection against Noise on Control Pins (\overline{CE} , \overline{OE} , \overline{WE}) during Operation. During readout or standby, noise on the control pins may act as a trigger and turn the EEPROM to programming mode by mistake. To prevent this phenomenon, the AS58C1001 has a noise cancellation function that cuts noise if its width is 20ns or less in programming mode. Be careful not to allow noise of a width of more than 20ns on the control pins.

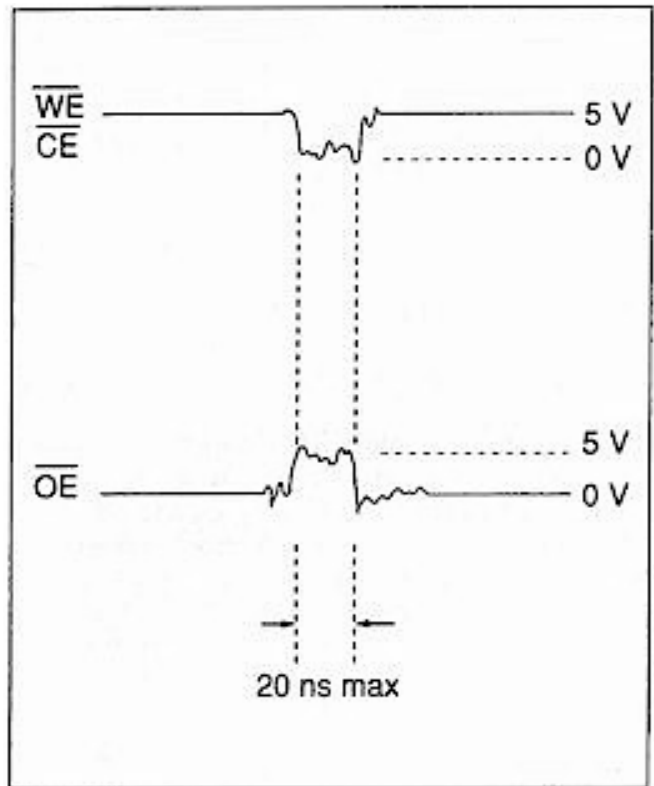

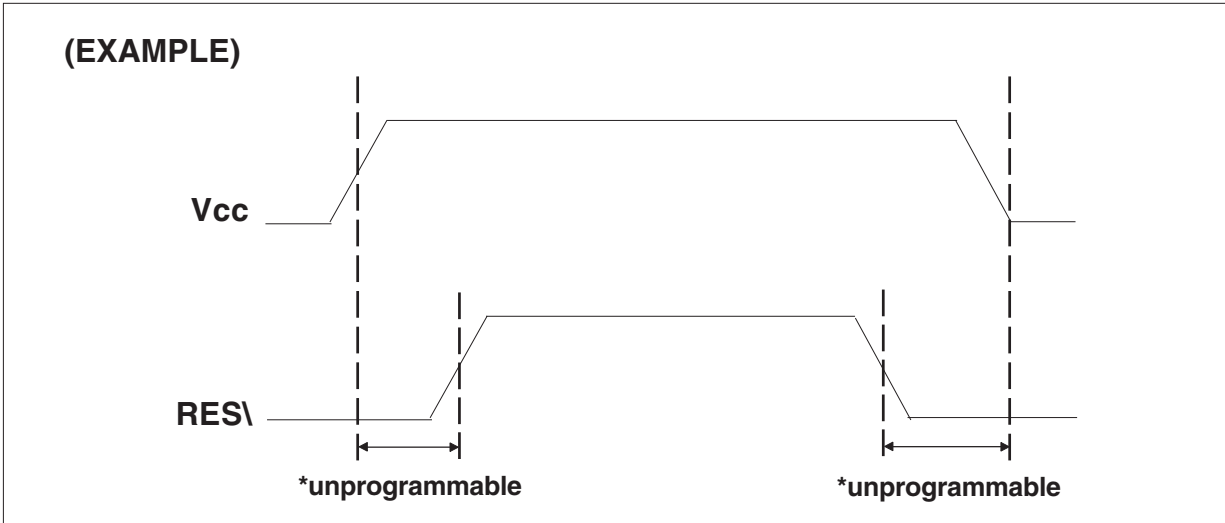

FUNCTIONAL DESCRIPTION (continued)

DATA PROTECTION (continued)

2. Data protection at Vcc on/off.

When RES\ is low, the EEPROM cannot be erased and programmed. Therefore, data can be protected by keeping RES\ low when Vcc is switched. RES\ should be high during programming because it does not provide a latch function. When Vcc is turned on or off, noise on the control pins generated by external circuits (CPU, etc.) may turn the EEPROM to programming mode by mistake. To prevent this unintentional programming, the EEPROM must be kept in an unprogrammable, standby or readout state by using a CPU reset signal to RES\ pin.

In addition, when RES\ is kept high at Vcc on/off timing, the input level of control pins (CE\, OE\, WE\) must be held as CE\=Vcc or OE\=LOW or WE\=Vcc level.

3. Software Data Protection

To protect against unintentional programming caused by noise generated by external circuits, AS58C1001 has a Software data protection function. To initiate Software data protection mode, 3 bytes of data must be input, followed by a dummy write cycle of any address and any data byte. This exact sequence switches the device into protection mode.

Write Address **Write Data**
(Normal Data Input)

5555	AA
↓	↓
2AAA	55
↓	↓
5555	A0

The Software data protection mode can be cancelled by inputting the following 6 Bytes. This changes the AS58C1001 to the Non-Protection mode, for normal operation.

Address	Data
5555	AA
↓	↓
2AAA	55
↓	↓
5555	80
↓	↓
5555	AA
↓	↓
2AAA	55
↓	↓
5555	20

ABSOLUTE MAXIMUM RATINGS*

Voltage on Vcc Supply Relative to Vss.....	-0.5V to +7.0V ¹
Voltage on any pin Relative to Vss.....	-0.6V to +7.0V ¹
Storage Temperature	-65°C to +150°C
Operating Temperature Range.....	-55°C to +125°C
Soldering Temperature Range.....	260°C
Maximum Junction Temperature**.....	+150°C
Power Dissipation.....	1.0W

*Stresses greater than those listed under "Absolute Maximum Ratings" may cause permanent damage to the device. This is a stress rating only and functional operation of the device at these or any other conditions above those indicated in the operation section of this specification is not implied. Exposure to absolute maximum rating conditions for extended periods may affect reliability.

** Junction temperature depends upon package type, cycle time, loading, ambient temperature and airflow.

ELECTRICAL CHARACTERISTICS AND RECOMMENDED DC OPERATING CONDITIONS

(-55°C ≤ T_A ≤ 125°C; V_{CC} = 5V ±10%)

PARAMETER	CONDITION	SYMBOL	MIN	MAX	UNITS	NOTES
Input High (Logic 1) Voltage		V _{IH}	2.2	V _{CC} + 0.3V	V	9
Input Low (Logic 0) Voltage ³		V _{IL}	-0.3	0.8	V	2
Input Voltage (RES\ Pin)		V _H	V _{CC} -0.5	V _{CC} +1.0	V	
Input Leakage Current ⁴	0V ≤ V _{IN} ≤ V _{CC}	I _{LI}	-2	2	μA	4
Output Leakage Current	Output(s) disabled, 0V ≤ V _{OUT} ≤ V _{CC}	I _{LO}	-2	2	μA	
Output High Voltage	I _{OH} = -400 μA	V _{OH}	2.4		V	
Output Low Voltage	I _{OL} = 2.1 mA	V _{OL}		0.4	V	

PARAMETER	CONDITIONS	SYM	MAX			UNITS	NOTES
			-15	-20	-25		
Power Supply Current: Operating	I _{OUT} =0mA, V _{CC} = 5.5V Cycle=1μS, Duty=100%	I _{CC3}	20	20	20	mA	
	I _{OUT} =0mA, V _{CC} = 5.5V Cycle=MIN, Duty=100%		65	55	50		
Power Supply Current: Standby	CE\=V _{CC} , V _{CC} = 5.5V	I _{CC1}	350	350	350	μA	
	CE\=V _{IH} , V _{CC} = 5.5V	I _{CC2}	3	3	3	mA	

CAPACITANCE

PARAMETER	CONDITIONS	SYMBOL	MAX	UNITS	NOTES
Input Capacitance	T _A = 25°C, f = 1MHz V _{IN} = 0	C _{IN}	6	pF	
Output Capacitance		C _O	12	pF	

AC ELECTRICAL CHARACTERISTICS FOR READ OPERATION

($-55^{\circ}\text{C} \leq T_c \leq 125^{\circ}\text{C}$; $V_{cc} = 5\text{V} \pm 10\%$)

Test Conditions

- Input Pulse Levels: 0.0V to 3.0V
- Input rise and fall times: $\leq 20\text{ns}$
- Output Load: 1 TTL Gate + 100pF (including scope and jig)
- Reference levels for measuring timing: 1.5V, 1.5V

ITEM DESCRIPTION	TEST CONDITION	SYMBOL	-15		-20		-25		UNITS
			MIN	MAX	MIN	MAX	MIN	MAX	
Address Access Time	$\text{CE}\backslash=\text{OE}\backslash=V_{\text{IL}}\text{WE}\backslash=V_{\text{IH}}$	t_{ACC}	---	150	---	200	---	250	ns
Chip Enable Access Time	$\text{OE}\backslash=V_{\text{IL}}\text{WE}\backslash=V_{\text{IH}}$	t_{CE}	---	150	---	200	---	250	ns
Output Enable Access Time	$\text{CE}\backslash=V_{\text{IL}}\text{WE}\backslash=V_{\text{IH}}$	t_{OE}	10	75	10	75	10	75	ns
Output Hold to Address Change	$\text{CE}\backslash=\text{OE}\backslash=V_{\text{IL}}\text{WE}\backslash=V_{\text{IH}}$	t_{OH}	0	---	0	---	0	---	ns
Output Disable to High-Z	$\text{CE}\backslash=V_{\text{IL}}\text{WE}\backslash=V_{\text{IH}}$	t_{DF}	0	50	0	50	0	50	ns
	$\text{CE}\backslash=\text{OE}\backslash=V_{\text{IL}}\text{WE}\backslash=V_{\text{IH}}$	t_{DFR}	0	350	0	350	0	350	ns
RES\ to Output Delay	$\text{CE}\backslash=\text{OE}\backslash=V_{\text{IL}}\text{WE}\backslash=V_{\text{IH}}$	t_{RR}	0	450	0	450	0	450	ns

AC ELECTRICAL CHARACTERISTICS FOR SOFTWARE DATA PROTECTION CYCLE OPERATION

PARAMETER	SYMBOL	MIN	MAX	UNITS
Byte Load Cycle Time	t_{BLC}	0.55	30	μS
Write Cycle Time	t_{WC}	10	---	mS

AC ELECTRICAL CHARACTERISTICS FOR DATA\ POLLING OPERATION

PARAMETER	SYMBOL	MIN	MAX	UNITS
Output Enable Hold Time	t_{OEH}	0	---	ns
Output Enable to Write Setup Time	t_{OES}	0	---	ns
Write Start Time	t_{DW}	150	---	ns
Write Cycle Time	t_{WC}	---	10	ms

AC ELECTRICAL CHARACTERISTICS FOR PAGE ERASE AND PAGE WRITE OPERATIONS

PARAMETER	SYMBOL	MIN	MAX	UNITS
Address Setup Time	t_{AS}	0	---	ns
Write Enable to Write Setup Time	t_{WS}^8	0	---	ns
Chip Enable to Write Setup Time	t_{CS}^7	0	---	ns
Write Pulse Width	t_{WP}^7	250	---	ns
	t_{CW}^9	250	---	ns
Address Hold Time	t_{AH}	150	---	ns
Data Setup Time	t_{DS}	100	---	ns
Data Hold Time	t_{DH}	10	---	ns
Write Enable Hold Time	t_{WH}^8	0	---	ns
Chip Enable Hold Time	t_{CH}^7	0	---	ns
Out Enable to Write Setup Time	t_{OES}	0	---	ns
Output Enable Hold Time	t_{OEH}	0	---	ns
Data Latch Time	t_{DL}	200	---	ns
Write Cycle Time	t_{WC}	10	---	ms
Byte Load Window	t_{BL}	100	---	μs
Byte Load Cycle	t_{BLC}	0.55	30	μs
Time to Device Busy	t_{DB}	120	---	ns
RES\ to Write Setup Time	t_{RP}	100	---	μs
Vcc to RES\ Setup Time	t_{RES}^{11}	1	---	μs

AC ELECTRICAL CHARACTERISTICS FOR BYTE ERASE AND BYTE WRITE OPERATIONS

PARAMETER	SYMBOL	MIN	MAX	UNITS
Address Setup Time	t_{AS}	0	---	ns
Chip Enable to Write Setup Time	t_{CS}^7	0	---	ns
Write Pulse Width	t_{CW}^8	250	---	ns
	t_{WP}^7	250	---	ns
Address Hold Time	t_{AH}	150	---	ns
Data Setup Time	t_{DS}	100	---	ns
Data Hold Time	t_{DH}	10	---	ns
Chip Enable Hold Time	t_{CH}^7	0	---	ns
Out Enable to Write Setup Time	t_{OES}	0	---	ns
Output Enable Hold Time	t_{OEH}	0	---	ns
Write Cycle Time	t_{WC}	10	---	ms
Byte Load Window	t_{BL}	100	---	μs
Time to Device Busy	t_{DB}	120	---	ns
RES\ to Write Setup Time	t_{RP}	100	---	μs
Vcc to RES\ Setup Time	t_{RES}^{10}	1	---	μs

AC TEST CONDITIONS

Input Pulse Levels.....	0V to 3V
Input Rise and Fall Times.....	$\leq 20ns$
Input Timing Reference Level.....	1.5V
Output Reference Level.....	1.5V
Output Load.....	See Figure 1

NOTES:

1. Relative to V_{SS}
2. V_{IN} min = -3.0V for pulse widths $\leq 50ns$
3. V_{IL} min = -1.0V for pulse widths $\leq 50ns$
4. I_{IL} on RES\ = 100ua MAX
5. t_{OF} is defined as the time at which E the output becomes and open circuit and data is no longer driven.
6. Use this device in longer cycle than this value
7. WE\ controlled operation
8. CE\ controlled operation
9. RES\ pin V_{IH} is V_H
10. Reference only, not tested

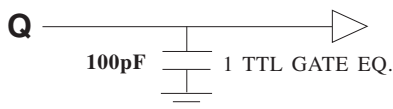
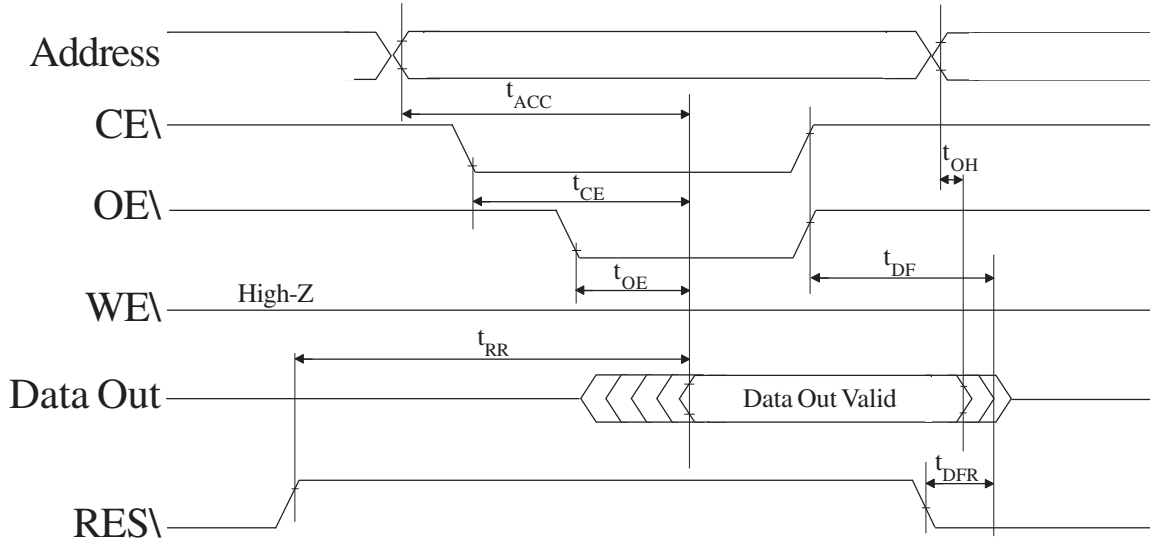
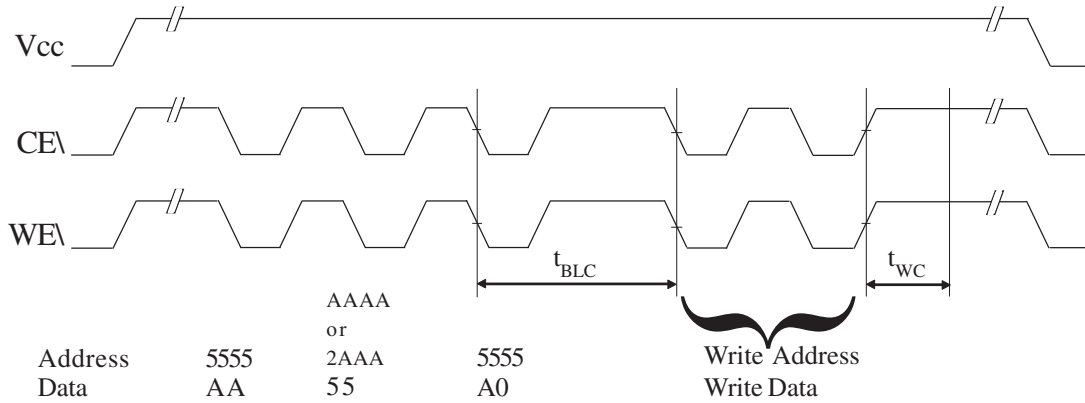

Figure 1
OUTPUT LOAD EQUIVALENT

READ TIMING WAVEFORM



SOFTWARE DATA PROTECTION TIMING WAVEFORM (protection mode)



SOFTWARE DATA PROTECTION TIMING WAVEFORM (non-protection mode)

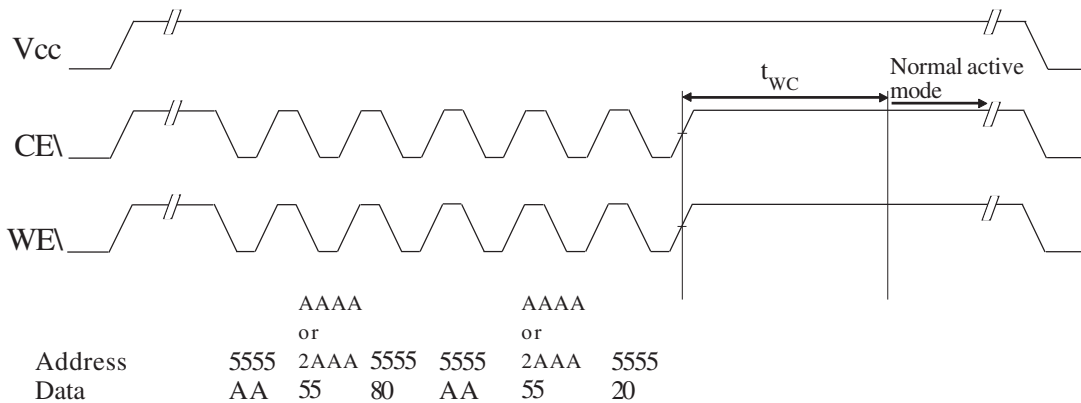

DATA\ POLLING TIMING WAVEFORM

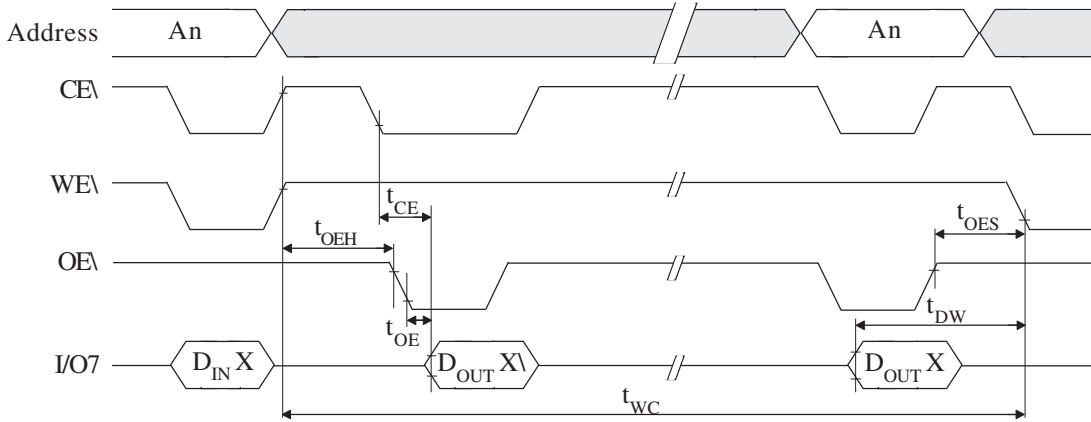

TOGGLE BIT WAVEFORM

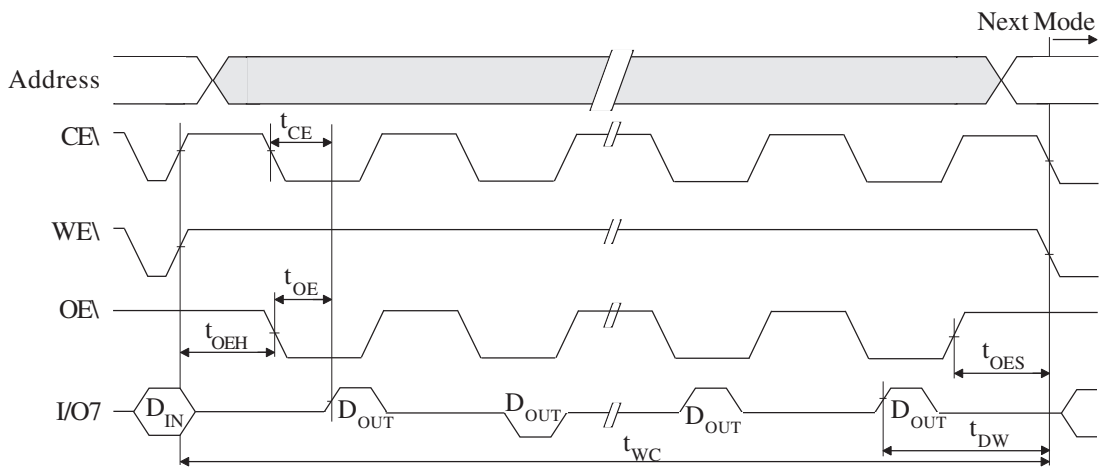

 In transition from HI to LOW or LOW to HI.

PAGE WRITE TIMING WAVEFORM
(WE\ CONTROLLED)

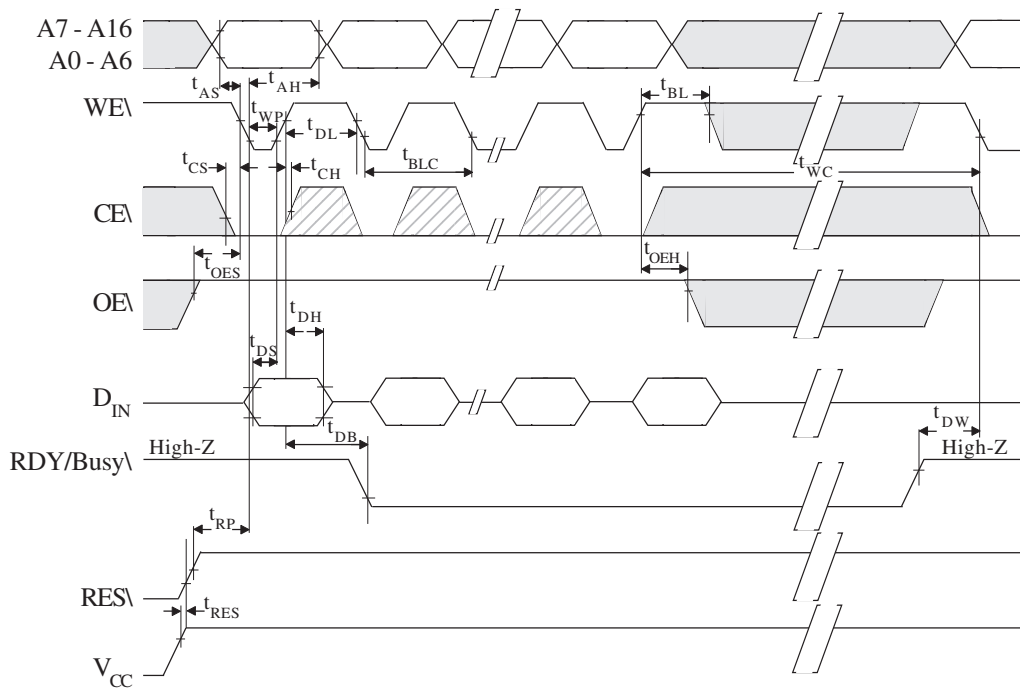

 In transition from HI to LOW or LOW to HI.

**PAGE WRITE TIMING WAVEFORM
(CE\ CONTROLLED)**

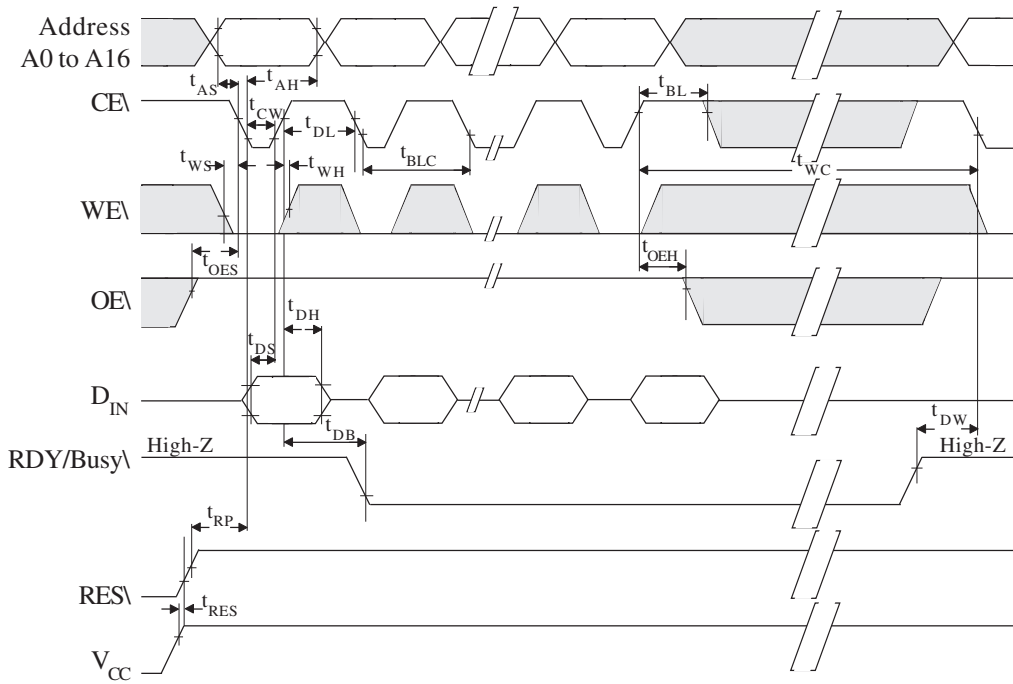

 In transition from HI to LOW or LOW to HI.

BYTE WRITE TIMING WAVEFORM
(WE\ CONTROLLED)

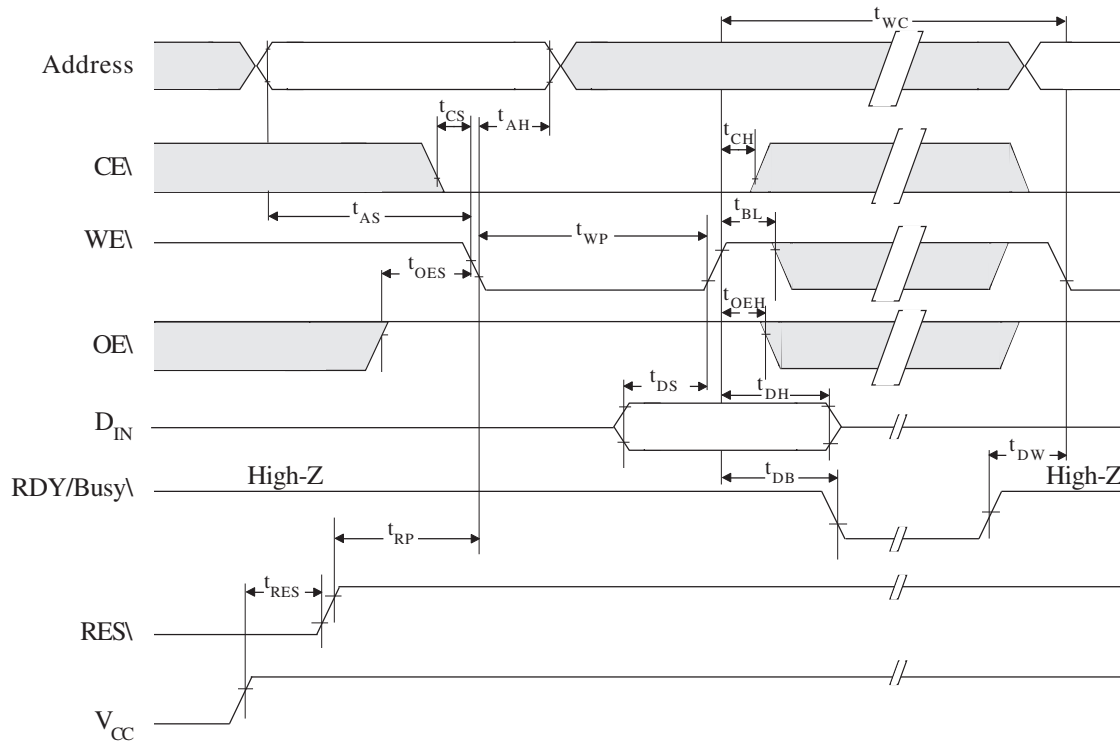

 In transition from HI to LOW or LOW to HI.

**BYTE WRITE TIMING WAVEFORM
(CE\ CONTROLLED)**

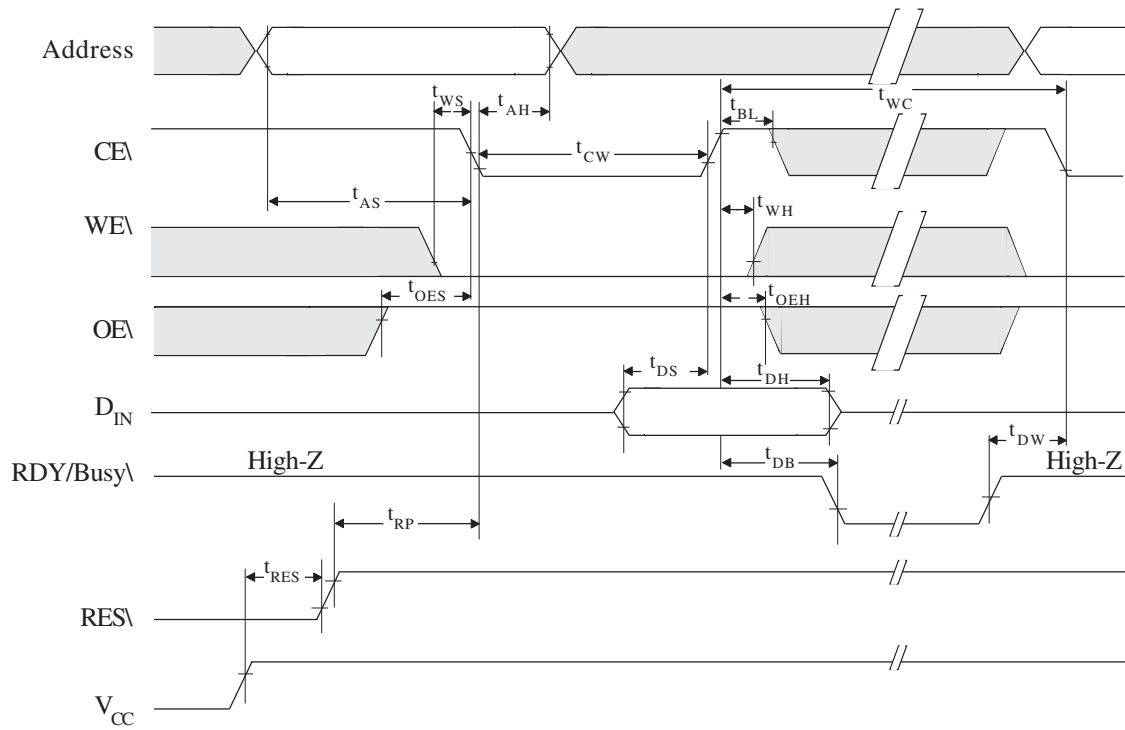

 In transition from HI to LOW or LOW to HI.

MECHANICAL DEFINITIONS*

ASI Case #305 (Package Designator SF)

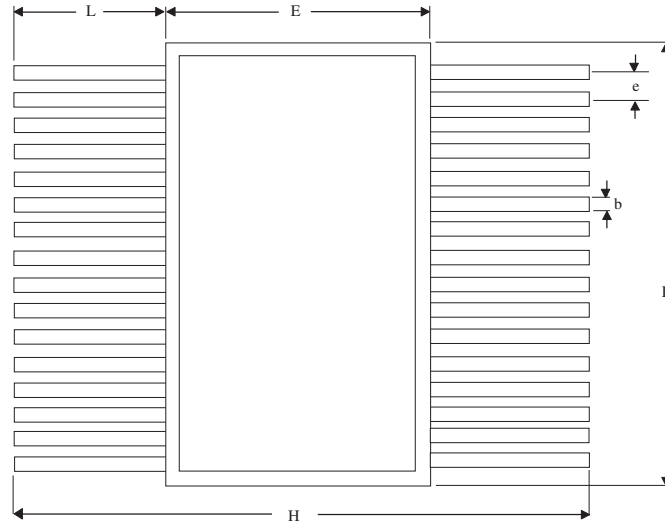

Top View

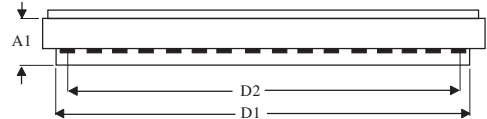
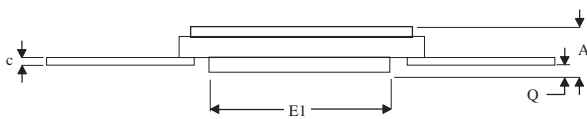

SYMBOL	SMD SPECIFICATIONS	
	MIN	MAX
A	0.125	0.150
A1	0.090	0.110
b	0.015	0.019
c	0.003	0.007
D	0.810	0.830
D1	0.775	0.785
D2	0.745	0.755
E	0.425	0.445
E1	0.290	0.310
e	0.045	0.055
H	1.000	1.100
L	0.290	0.310
Q	0.026	0.037

*All measurements are in inches.

MECHANICAL DEFINITIONS*

ASI Case #306 (Package Designator F)

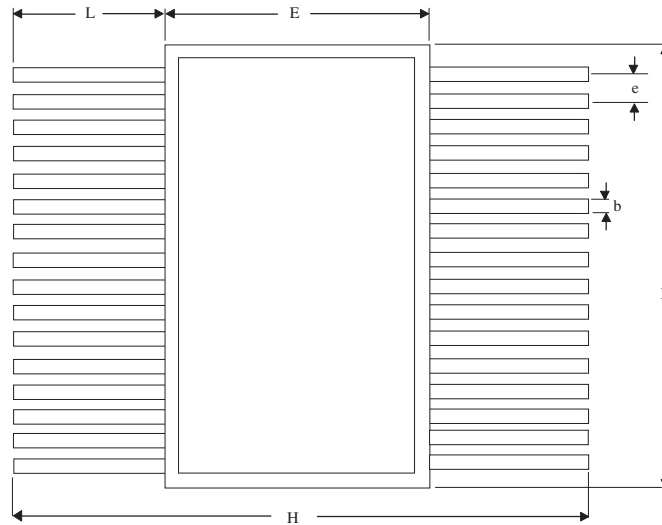

Top View

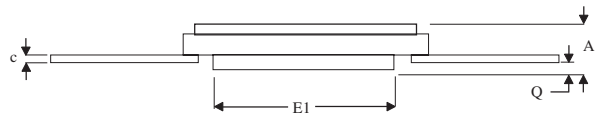
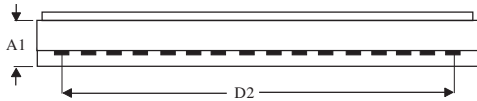

SYMBOL	SMD SPECIFICATIONS	
	MIN	MAX
A	0.097	0.123
A1	0.090	0.110
b	0.015	0.019
c	0.003	0.007
D	0.810	0.830
D2	0.745	0.755
E	0.425	0.445
E1	0.330	0.356
e	0.045	0.055
H	1.000	1.100
L	0.290	0.310
Q	0.026	0.037

NOTE: All drawings are per the SMD. ASI's package dimensional limits may differ, but they will be within the SMD limits.

*All measurements are in inches.

MECHANICAL DEFINITIONS*

ASI Case #508 (Package Designator DCJ)

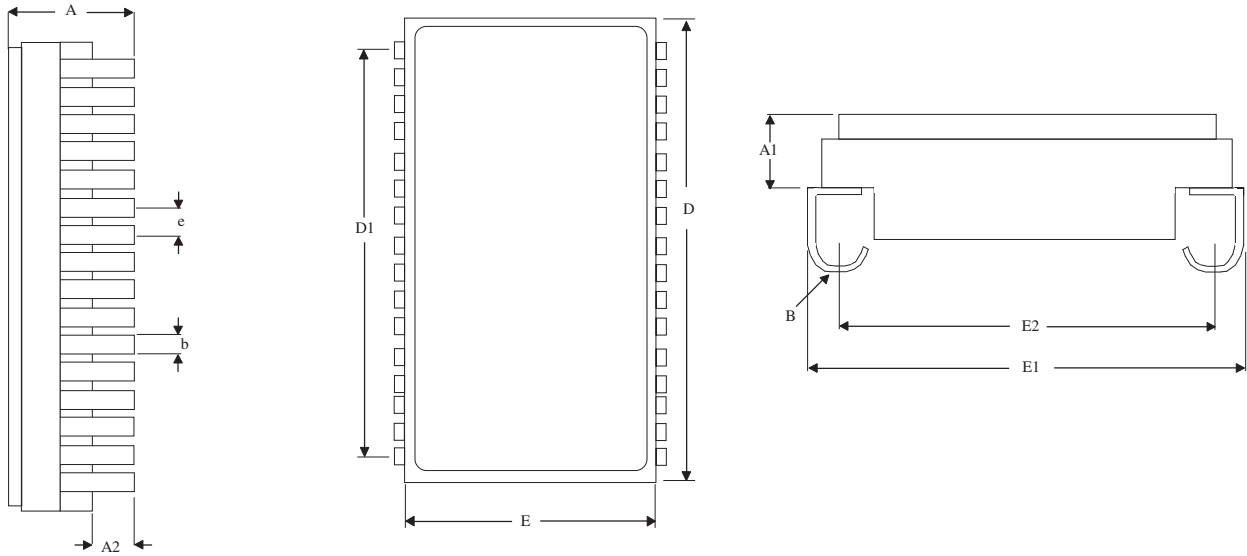

SYMBOL	ASI PACKAGE SPECIFICATIONS	
	MIN	MAX
A	0.132	0.142
A1	0.076	0.086
A2	0.018	0.028
B	0.018	0.032
b	0.015	0.019
D	0.816	0.834
D1	0.745	0.755
E	0.430	0.440
E1	0.465	0.485
E2	0.415	0.425
e	0.045	0.055

*All measurements are in inches.

MECHANICAL DEFINITIONS*

ASI Case (Package Designator DG)

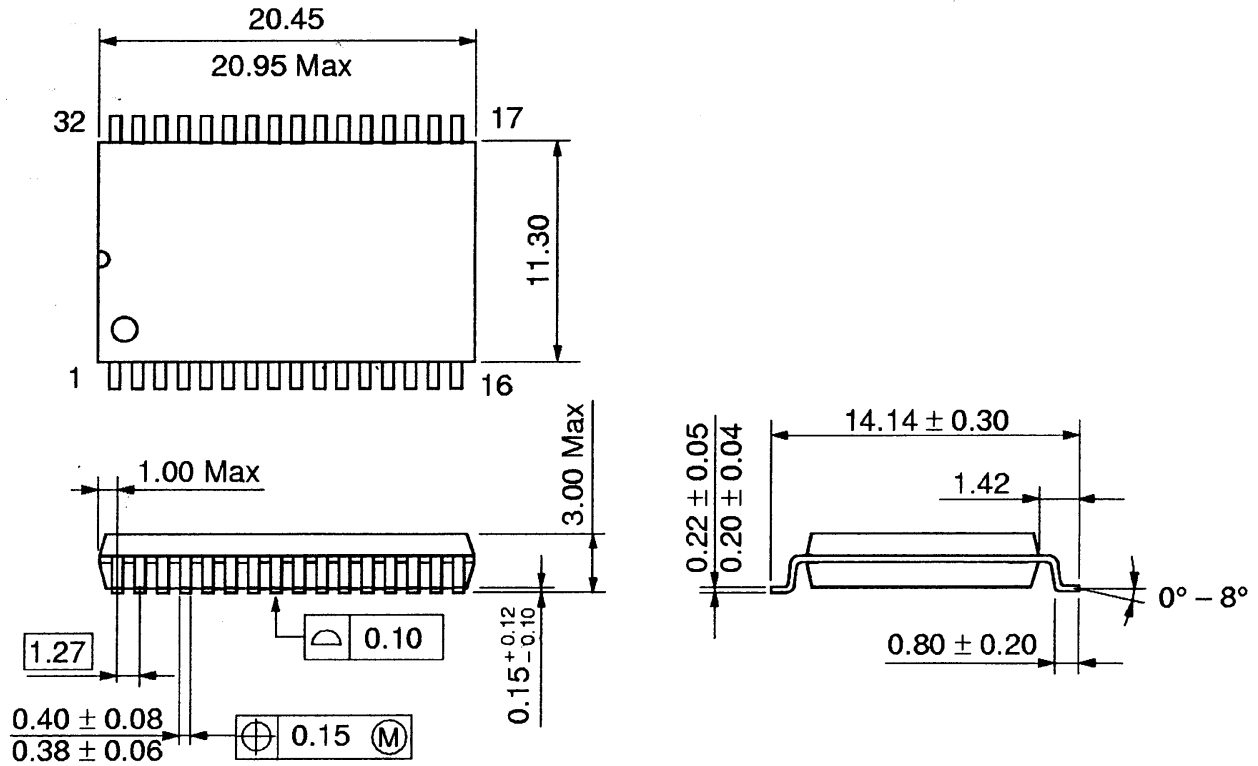

*All measurements are in millimeters.

ORDERING INFORMATION

EXAMPLE: AS58C1001SF-15/IT

Device Number	Package Type	Speed ns	Process
AS58C1001	SF	-15	/*
AS58C1001	SF	-20	/*
AS58C1001	SF	-25	/*

EXAMPLE: AS58C1001F-25/883C

Device Number	Package Type	Speed ns	Process
AS58C1001	F	-15	/*
AS58C1001	F	-20	/*
AS58C1001	F	-25	/*

EXAMPLE: AS58C1001DG-15/XT **

Device Number	Package Type	Speed ns	Process
AS58C1001	DG	-15	/*
AS58C1001	DG	-20	/*
AS58C1001	DG	-25	/*

EXAMPLE: AS58C1001DCJ-20/IT

Device Number	Package Type	Speed ns	Process
AS58C1001	DCJ	-15	/*
AS58C1001	DCJ	-20	/*
AS58C1001	DCJ	-25	/*

*AVAILABLE PROCESSES

IT = Industrial Temperature Range -40°C to +85°C
 XT = Extended Temperature Range -55°C to +125°C
 883C = Full Military Processing -55°C to +125°C

****NOTE:** DG package available as XT and IT only.



Austin Semiconductor, Inc.

EEPROM
AS58C1001

DOCUMENT TITLE

128K x 8 EEPROM

<u>Rev #</u>	<u>History</u>	<u>Release Date</u>	<u>Status</u>
5.5	Removed ECA Package	December 2008	Release
5.6	Removed 5962 references	November 2009	Release